

Advances in Land Based Optical Telescopes

On the impending death of the Hubble Space Telescope

Larry Wittig
Lexington Computer and Technology Group
27 March 2013



Golden Age of Astrometry

- Many astronomers believe that we are now living in the Golden age of astrometry – not only are we refining what we learned earlier but we are making fantastic new discoveries. Just 20 years ago we were wondering if there were extra-solar planets, but we have now identifies more than 861 (per Wikipedia). →
- Most of this is because advances in computers and technology have allowed us to design, build and operate better telescopes in space and on earth.
- Astrometry is an observational science. What we know about anything beyond our atmosphere comes to us by way of electro-magnetic radiation, and that is observed by telescopes of various types and analyzed by attached instruments.
 - In 1610, the year after Galileo Galilei first turned a telescope to the sky, he became the very first person to observe Jupiter's moons and Saturn's rings.
 - Neptune was also determined to be something other than a star by Galileo in 1612.
 - In summary all we knew before 1600 is that there were stars and planets out to Saturn. Some were not even sure whether or not the earth revolved around the sun.

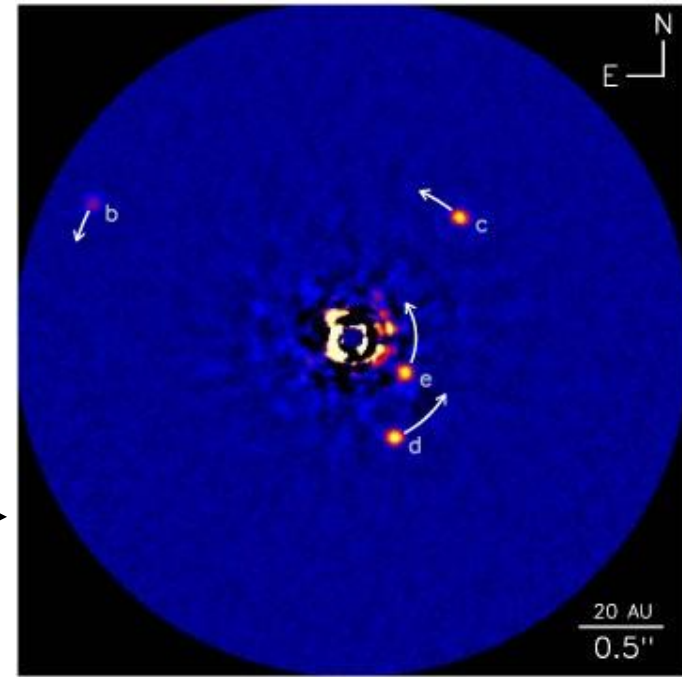

HR 8799 observed from Keck II telescope

Major Milestones in Land-based Telescopes



Newton's Reflector (~1668)



Mt. Wilson's Hooker 2.5 m Telescope (1917) used by Edwin Hubble to discover the expanding universe (1929)

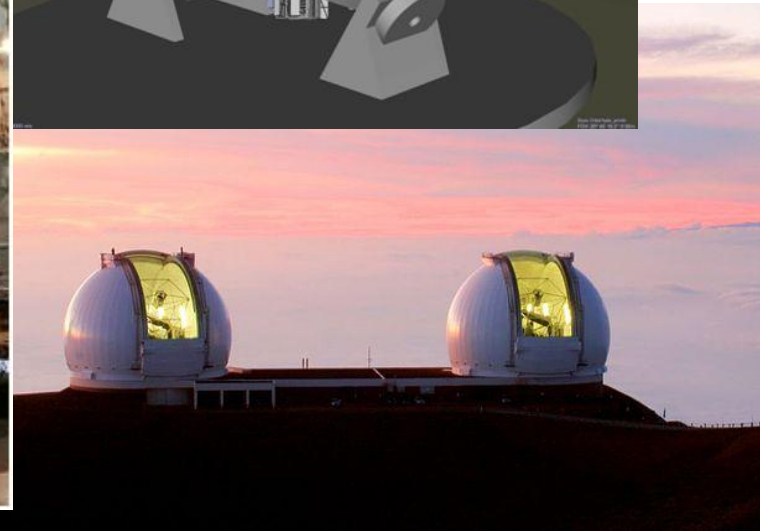
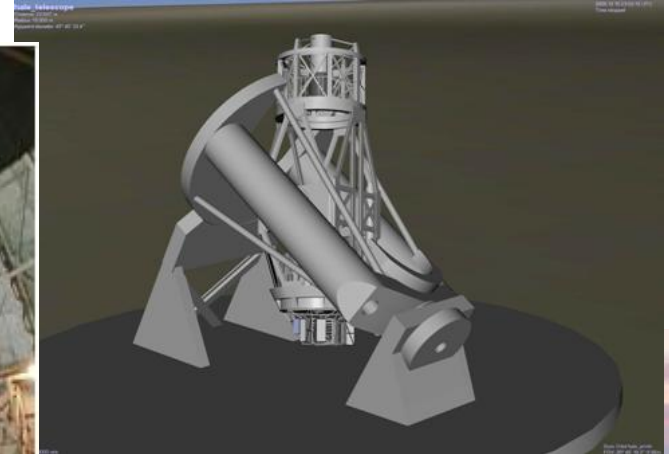

Hale 5m (1949) Mt. Palomar and Keck 10m Telescopes (1993 & 1996) Mauna Kea, Hawaii

Astrometry/Astrophysics is an observational science: to better understand how the universe has evolved we need better telescopes.

The Electromagnetic Spectrum

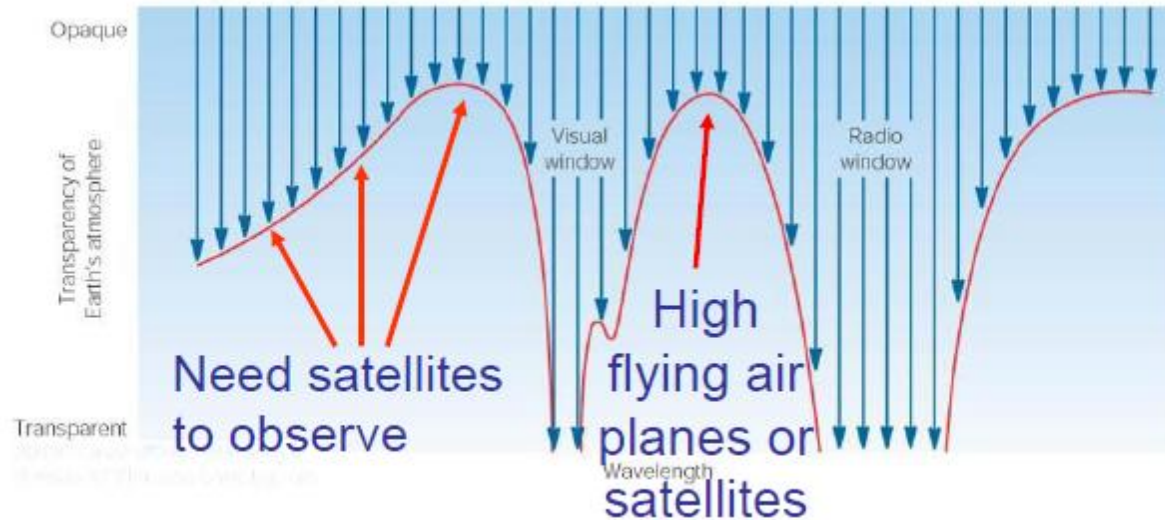
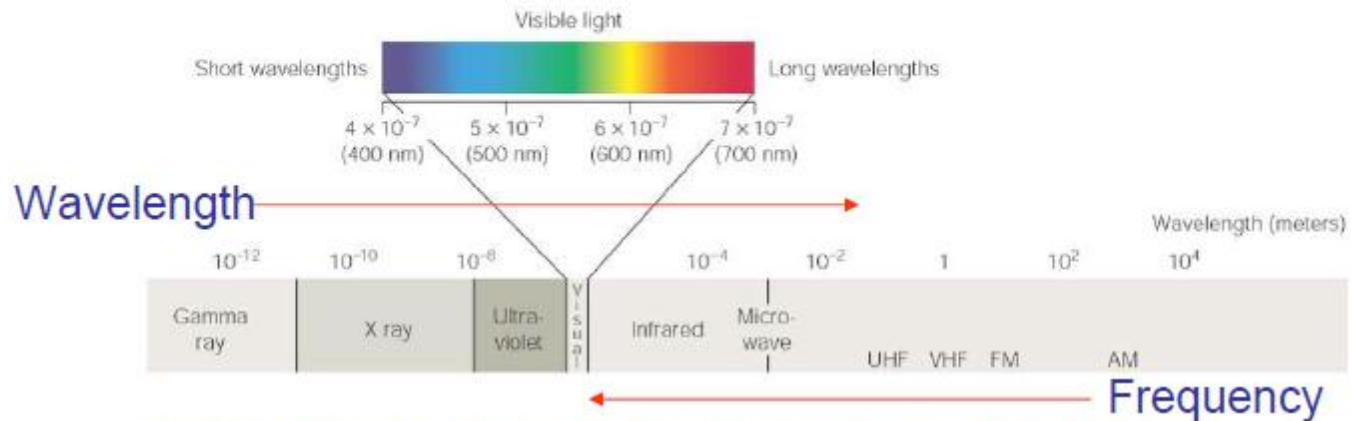

Atmospheric Absorption

From: <http://www.skepticalscience.com/does-greenhouse-effect-exist-intermediate.htm>

Different types of Telescopes or other probes are needed based on the part of the spectrum you want to view or study.

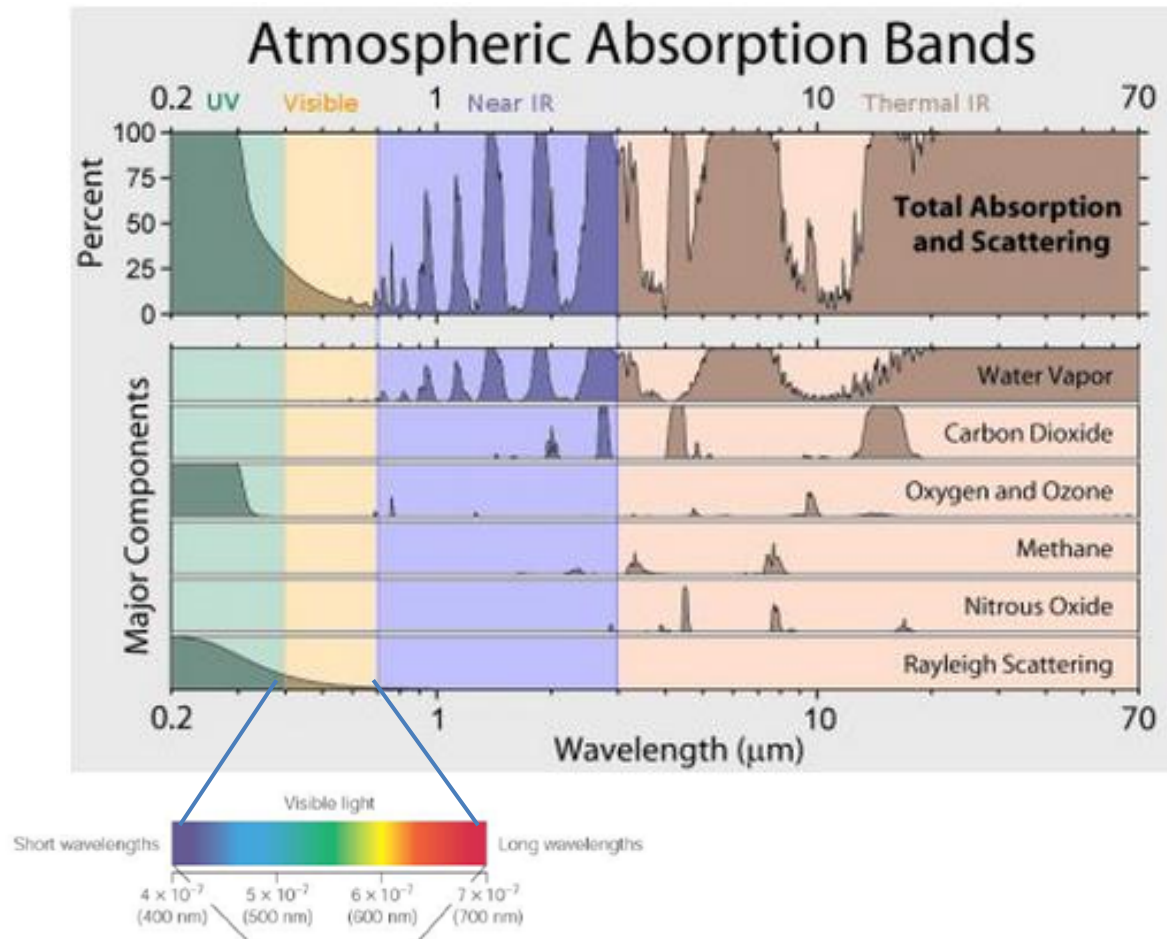

Major Types of Telescopes (p. 1 of 5)

Gamma ray, X-rays & Short WL Ultraviolet

X-ray and gamma-ray detection methods using mirrors and CCD devices do not work. Instead, individual X-ray and gamma-ray photons are counted by electronic detectors on board an orbiting device some of them like an array of Geiger counters. They can also use special CCDs and micro-channel detectors. See:

http://chandra.harvard.edu/about/science_instruments.html

Ultraviolet

- Intermediate UV wavelengths use optical mirror like stages to concentrate the light but bounce it off multiple (~4) diffraction gratings to separate wavelengths (See: http://en.wikipedia.org/wiki/Hopkins_Ultraviolet_Telescope), and
- Long UV wavelengths can use optical telescope technology but with modified mirror coatings, e.g., the Hubble telescope.

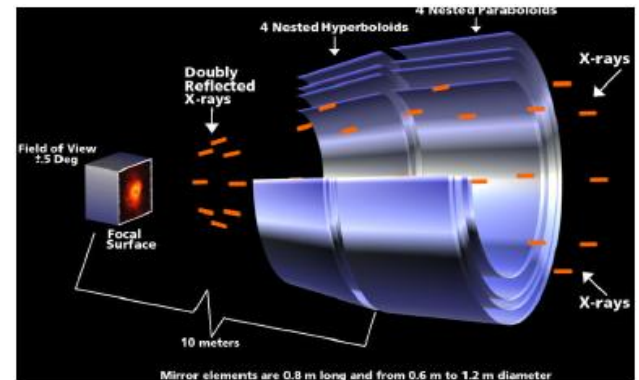

Gamma-ray detection

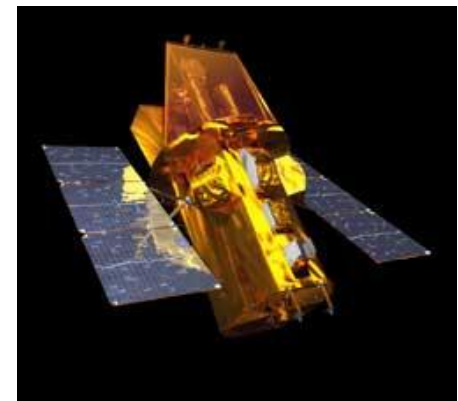

Swift Gamma-Ray Burst Mission

Chandra X-Ray Telescope



Major Types of Telescopes

(p. 2 of 5)

Optical and near IR wavelengths

Refractors work by bending light as it passes thru two or more curved transparent lenses.

Not used in any new astronomical telescopes. For a given aperture refractors need to be very long and they suffer from **chromatic aberration**. With considerable refinements refractors are used for most telephoto photography lenses.

Reflectors work by reflecting light off curved mirrors.

Advantages – eliminates chromatic aberration, more compact and the overall structure is more rigid, thinner back supported lens, only the surface needs to be good, lend themselves to simpler supporting structures, multiple segmentation, and they can incorporate active mirror optics systems. There is a large number of variations of reflectors, however most large telescopes are of the A Ritchey-Chretien design.

(see: http://en.wikipedia.org/wiki/Reflecting_telescope)

The 40-inch (1 m) Refractor, at Yerkes Observatory at 65' long is the largest refractor still in use.



A "portable" 40-inch Reflector.

A typical large reflector telescope

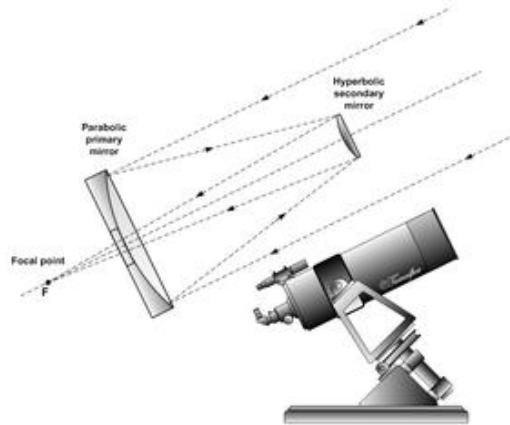

Most newer large telescopes have segmented mirrors. →

The struts holding the secondary mirror cause spikes on pictures of stars.

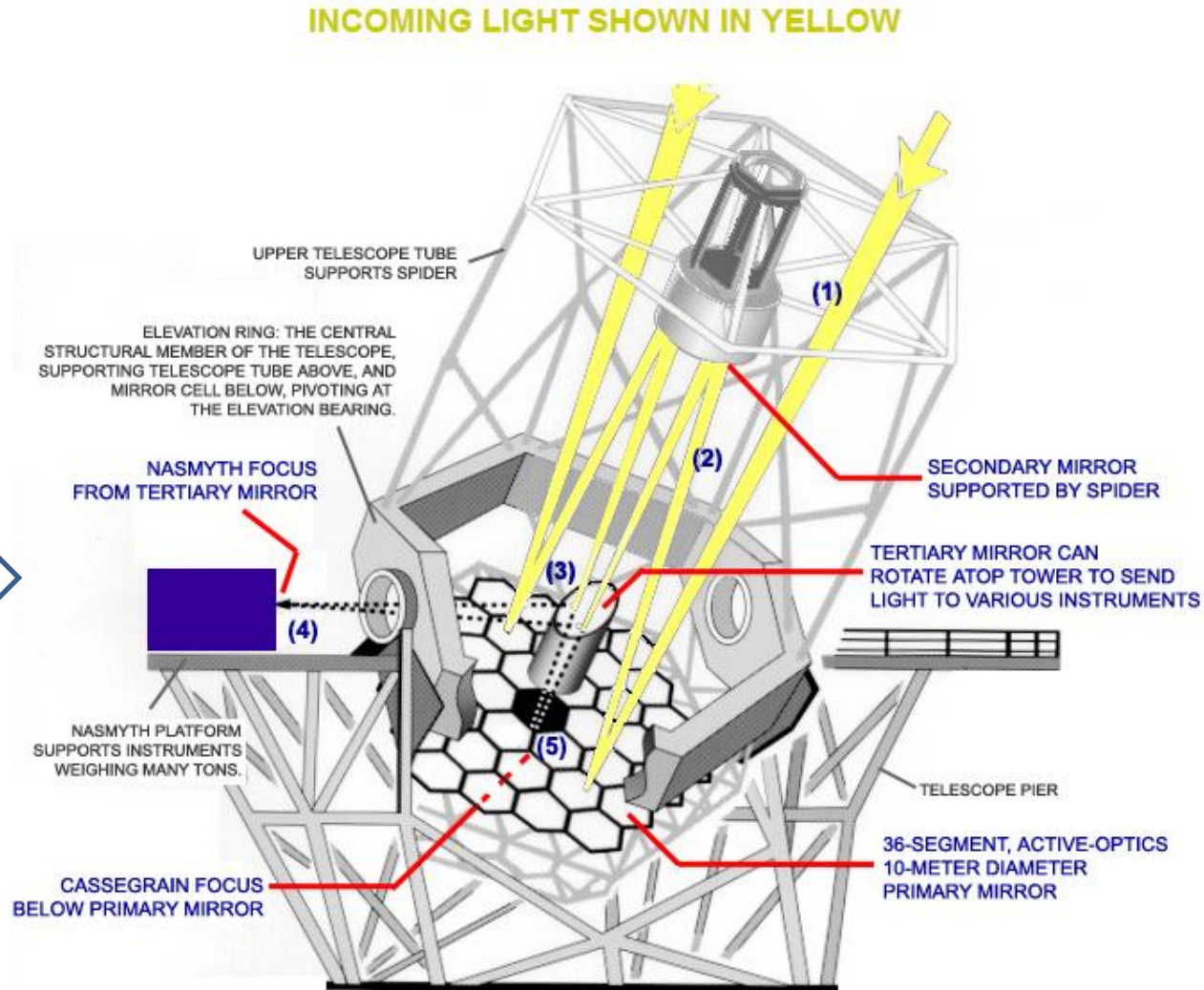

All major new telescopes are Ritchey-Chretien types, with a concave hyperbolic primary and a secondary mirrors. The advantage of this design is that both spherical aberration and coma are removed for a flat focal plane.

Major Types of Telescopes (p. 3 of 5)

Infrared

Near IR telescopes can be similar to optical reflector telescopes but made with special sensors (CMOS or CCD). Long wavelength IR is best measured above the atmosphere (see JWST). Images are colorized for viewing. These telescopes use superfluid liquid helium cryostats which run out over time.

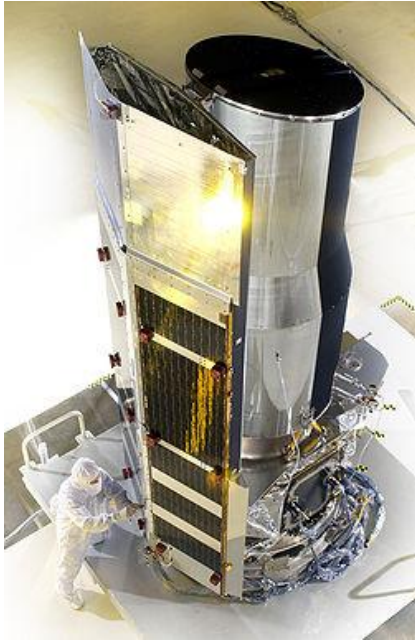

Spitzer Space Telescope

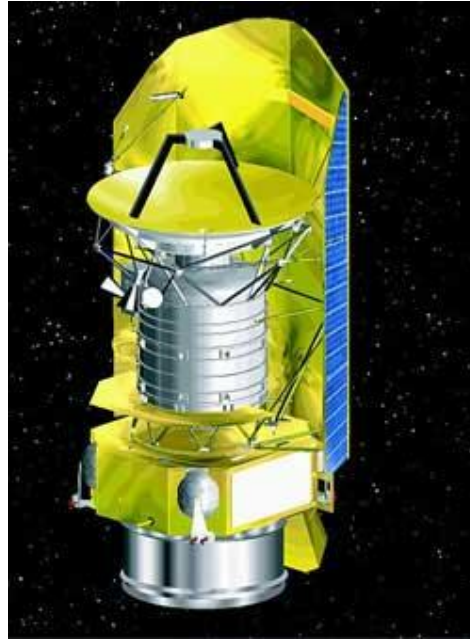

Herschel Space Observatory



Narrow bands of near-IR light penetrate the atmosphere and can be viewed from ground-based telescopes, but space-based telescopes are needed for long WL IR.

Major Types of Telescopes (p. 4a of 5)

Microwave Telescope

- Uses elliptical section of a paraboloid for reflectors, which avoids struts in front of the reflectors. (Struts would give off heat – i.e., microwaves)
- The μ waves are sensed by horn-like receivers that work at specific wavelengths.
- This probe looks in two opposite directions, and does a differential calculation.

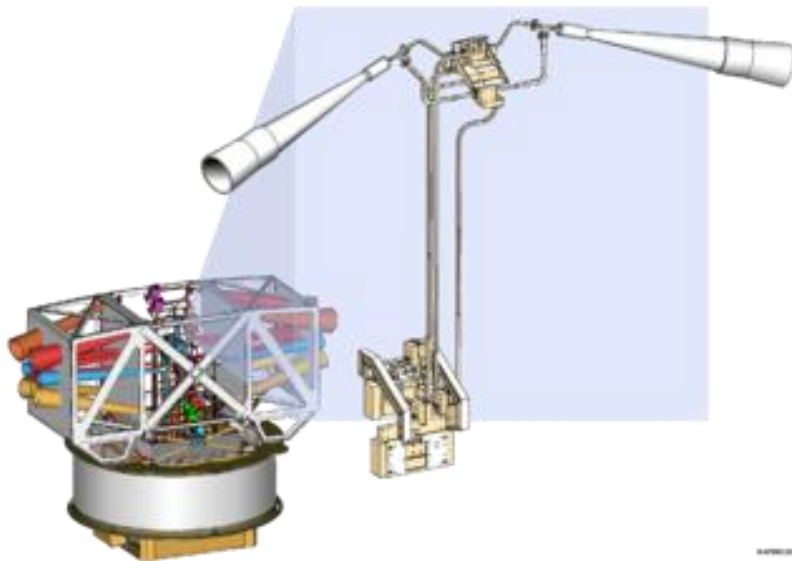

The Wilkinson Microwave Anisotropy Probe (WMAP) spacecraft and processed image.

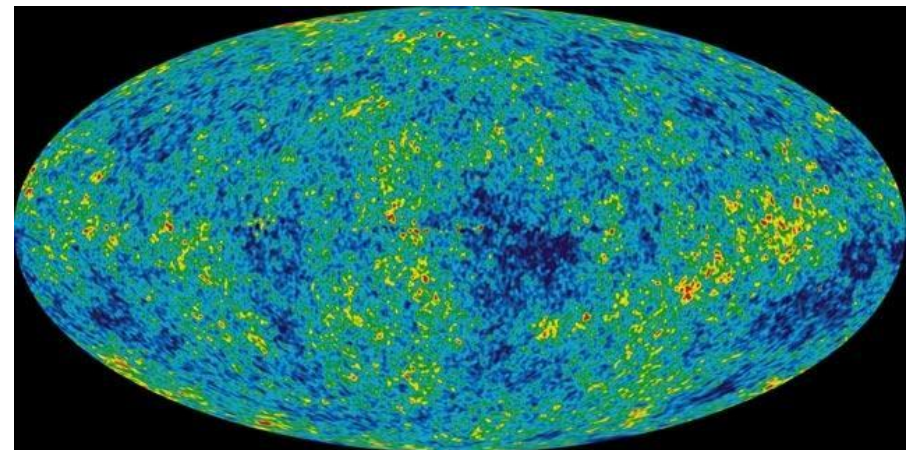

Major Types of Telescopes (p.5 of 5)

Radio Telescopes

- Can be and are usually land based
- Usually deployed in arrays, but there are exceptions
- Dishes are most common
- Dipole antennas are sometimes used

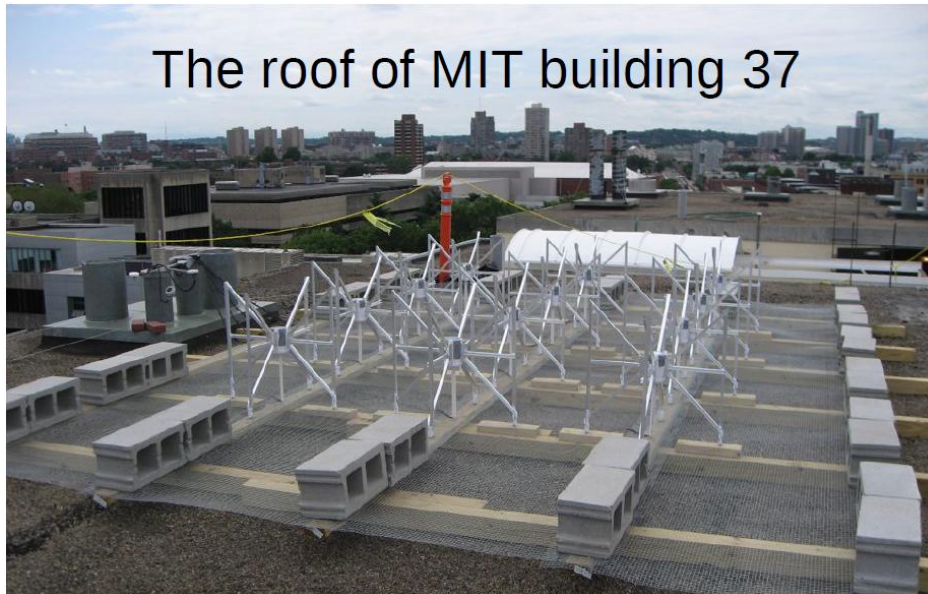

FFT Telescope Concept



A network of radio telescopes: The Very Large Array (VLA), New Mexico

Telescopic images from different telescope types

Different types of telescope, operating in different wavelength bands, provide different information about the same object. Together they provide a more comprehensive understanding.

Crab Nebula: Remnant of an Exploded Star (Supernova)

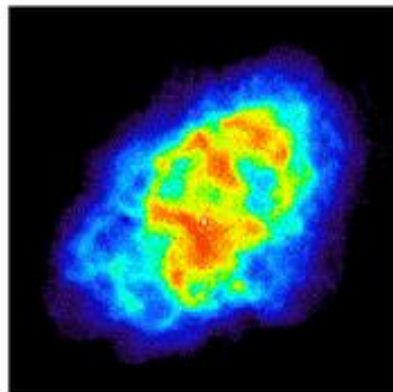

Radio wave (VLA)



Infrared radiation (Spitzer)



Visible light (Hubble)

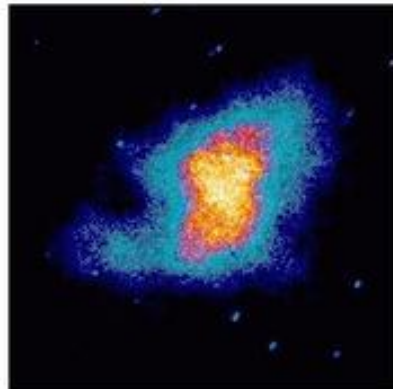

Ultraviolet radiation (Astro-1)



Low-energy X-ray (Chandra)

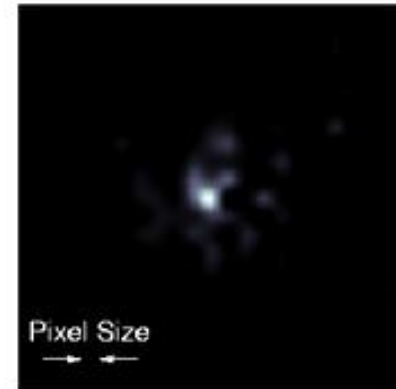

High-energy X-ray (HEFT)
*** 15 min exposure ***

Note that except for the visible light image the rest are colored.

From: <http://en.wikipedia.org/wiki/Telescope>

No more Hubble after all it's success?



Hubble eXtreme Deep Field (XDF)

The exposure time was two million seconds (23 days).

http://en.wikipedia.org/wiki/Hubble_Extreme_Deep_Field

http://www.youtube.com/watch?v=oAVjF_7ensg (4 min. video)

<http://www.youtube.com/watch?v=A4W7dvoWBGU> (18+ min.)

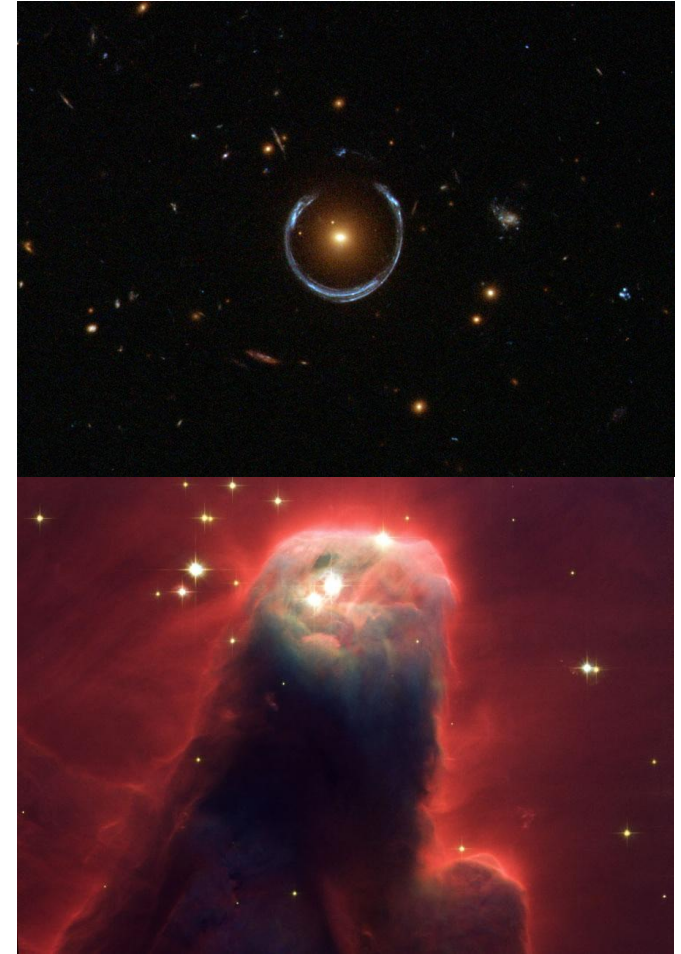

Top: Gravitational Lensing

Bottom: Cone Nebula

← Fly into the Ultra Deep Field

← How the XDF was made

Hubble's "replacement" the JWST

The main technical features of the JWST ([James West Space Telescope](#)) are a large and very cold 6.5-meter (vs. Hubble's 2.5 meter) diameter mirror, an observing position far from Earth, orbiting the Earth–Sun L₂ point. These features will give JWST unprecedented resolution and sensitivity from [long-wavelength \(orange\) visible to the mid-infrared](#). Hence, the JWST is [not a true optical telescope](#). The light gathering capacity of the JWST is approximately 7x greater than Hubble and 60x greater than Spitzer.



Above: Hubble

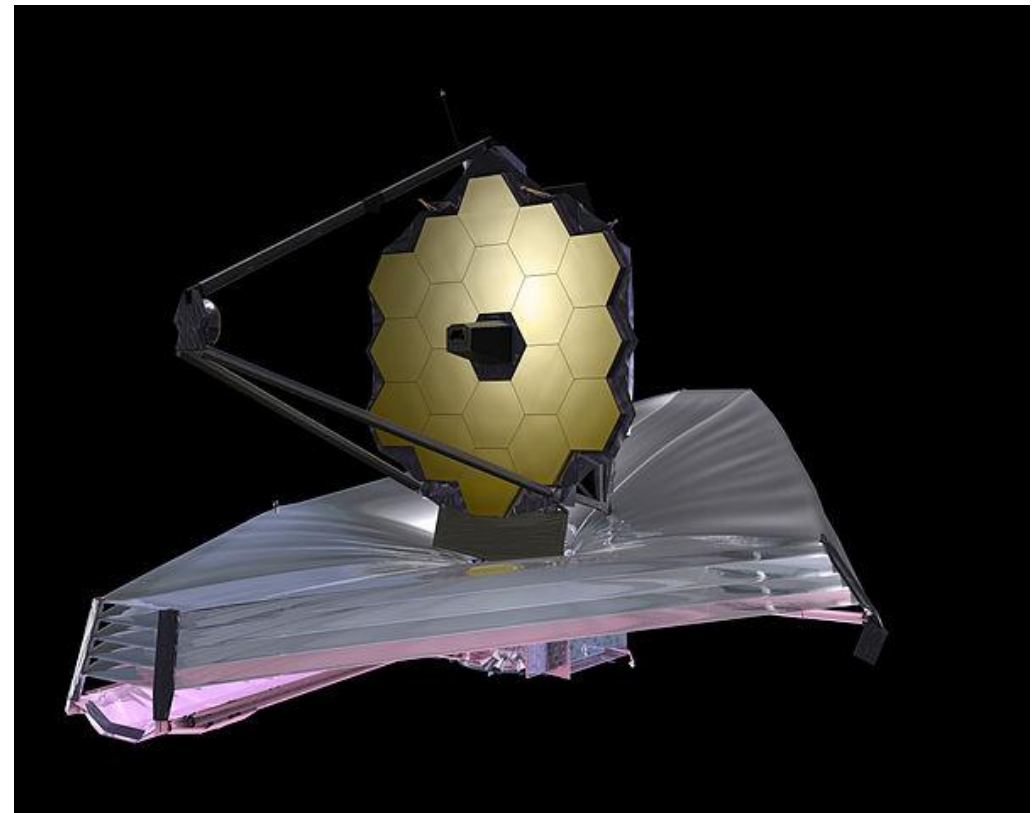

Right: JWST

NASA's Advanced Technology Large Aperture Space Telescope ([ATLAST](#)) concept, if ever launched, would be a replacement for Hubble.

The Best Land-based IR/optical telescopes are now better than Hubble

Image from the Hubble Space Telescope showing a bright star and surrounding stars. Photo courtesy of the Hubble Space Telescope

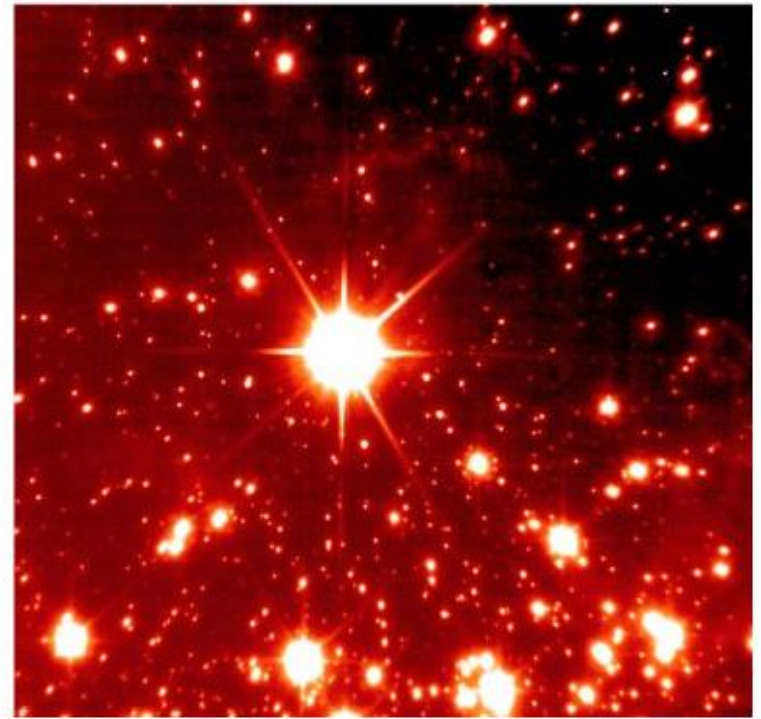
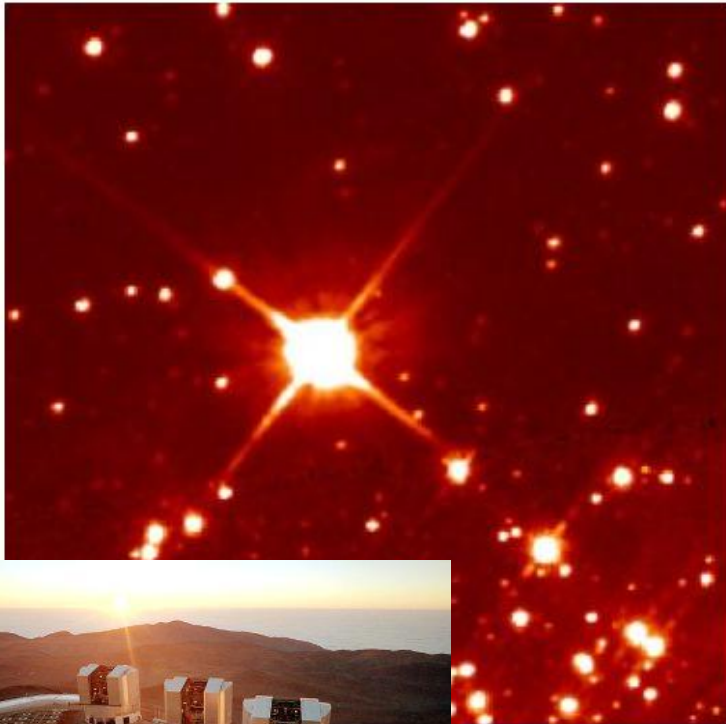

*Image from the Very Large Telescope taken using **Adaptive Optics**. There are more stars visible in this view and each star is clearly seen - not blurry - since the telescope is not only larger than the Hubble, but used adaptive optics. Photo from the [European Southern Observatory in Chile](#).*

Hubble vs. Keck view of Uranus

This is composite of visible light and infrared (the rings).

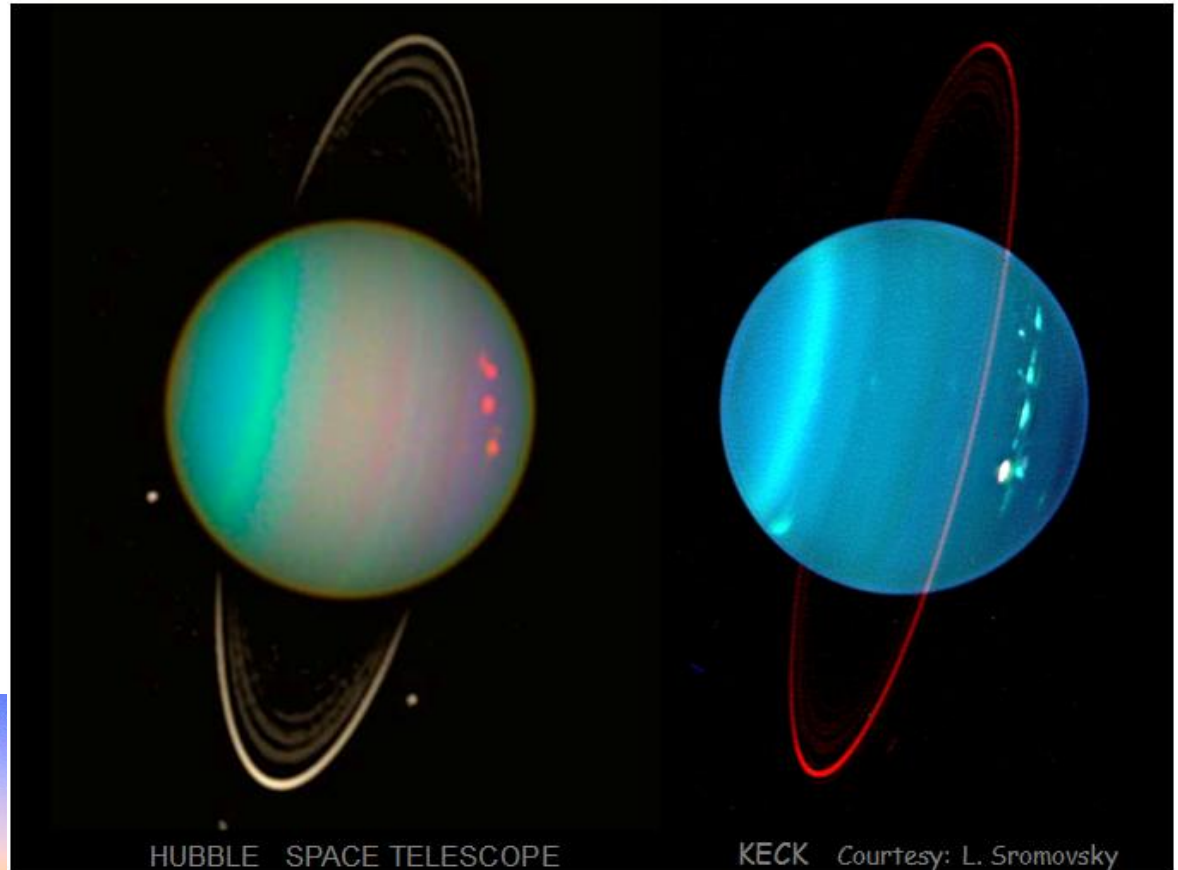

Mauna Kea is usually above the clouds, and in the winter time there's snow.

Improvements in Land-based Optical Telescopes

- Large aperture (usually segmented) mirrors
 - Hooker 100" (Mt. Wilson) ; GTC 410"; E-ELT (planned for ~2020) 1550"
 - Light gathering rate $\propto D^2$ (GTC/Hooker $\approx 16x$, E-ELT/Hooker $\approx 64x$)
 - Smaller diffraction limit (resolving power) $\propto \lambda/D^*$
- Large CDC sensors
 - Eyeball observation \Rightarrow film \Rightarrow small CDCs \Rightarrow large CDC arrays
- Active and Adaptive Optics (AO)
 - A large amount of AO information was declassified by military ~1990
 - Can be (and has been) implemented on older telescopes
 - Now improved with laser guide stars
- Location
 - Now large telescopes are located at the very best places in the world
 - High altitude, low background lighting , stiller air, less IR absorption

* A 10m telescope can resolve ~ 3 inches at 100 miles, low earth orbit. Or the difference between a softball and two and two baseballs at a Boston to Hartford distance.

Improvements in Land-based Optical Telescopes

- Post processing capabilities and Data processing magnitude
- Different Types
 - Field of view (high resolution narrow vs. wide field survey, e.g., LSST)
- Different Instruments and Filters
 - This is harder to do, and harder to upgrade in space
 - Some of these instruments alone are as large as a satellite
- Precision polishing (and re-polishing of segmented mirrors)
- Expense vs. Space Telescopes
 - The JWST is expected to cost \$9B vs. \$1.3B for the ground-based TMT (Thirty Meter Telescope) presently under development
 - Maintenance cost and upgrades are considerably less expensive for ground based telescopes
 - “U.S.” ground based telescopes are only partially funded by the government – they get a of NGOs funds

New telescopes use very large array CCD sensors



CCD cameras for astronomy (cont')

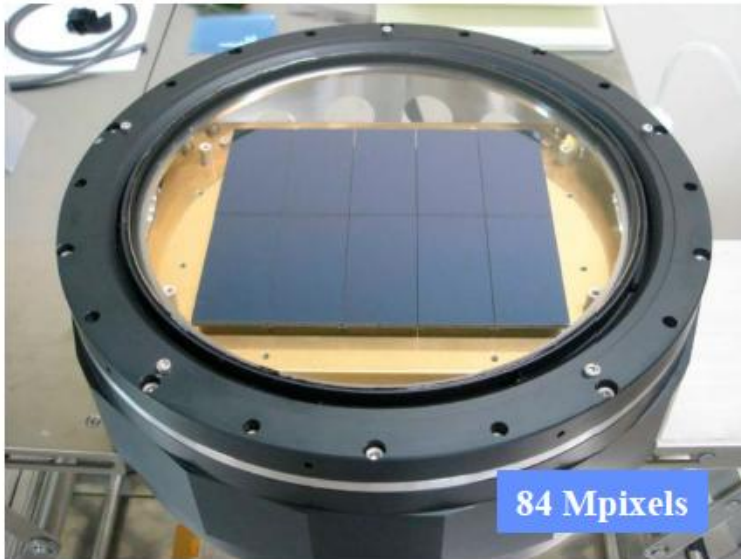

SuprimeCam – 10 2k x 4k, $(15\ \mu\text{m})^2$ -pixel CCDs
Subaru 8-m Telescope (2008)

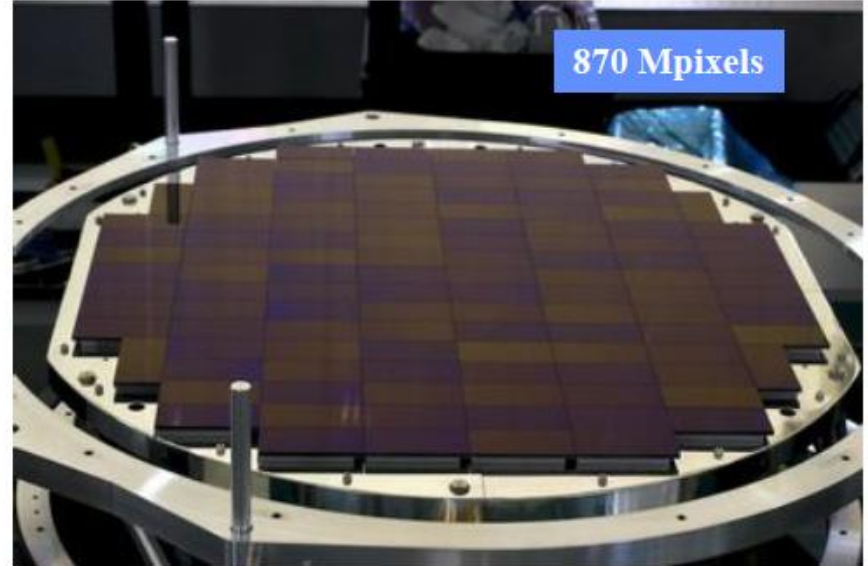

HyperSuprimeCam – 116 2k x 4k, $(15\ \mu\text{m})^2$ -pixel CCDs
Subaru 8-m Telescope
1st light achieved 28Aug2012

~ 200 μm thick, fully depleted CCDs

Hamamatsu Corporation

New telescopes use very large array CCD sensors.

Shown is a mock-up of the sensors for the **Large Synoptic Survey Telescope**

The CCD array is located on a cryostatically cooled cold backplane to reduce self noise.

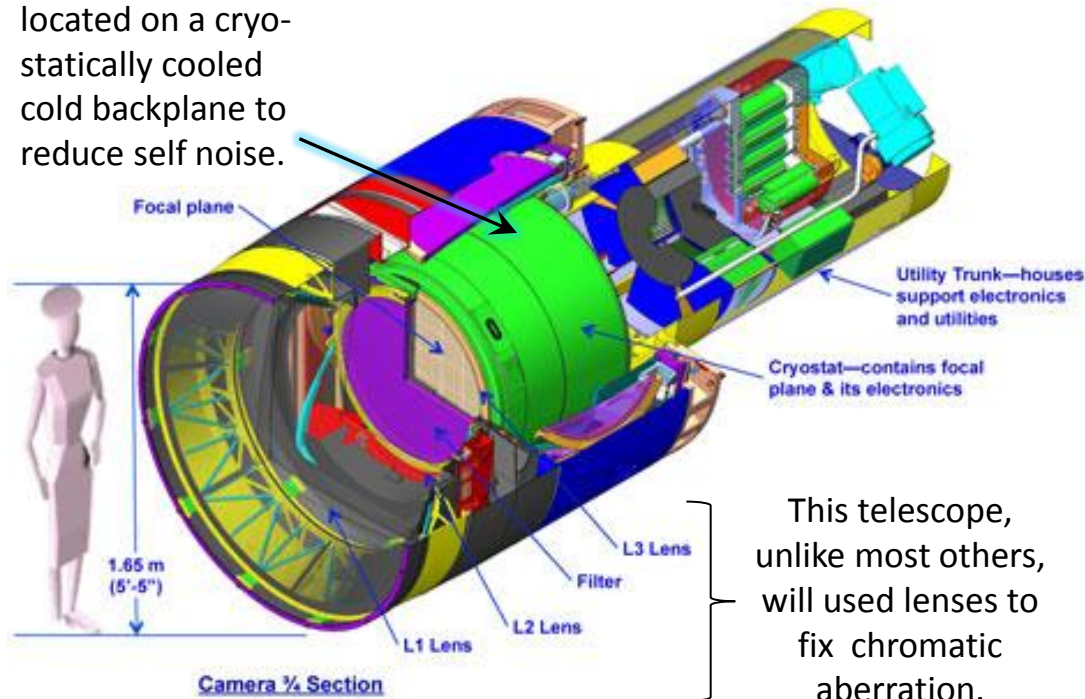

This telescope, unlike most others, will use lenses to fix chromatic aberration.

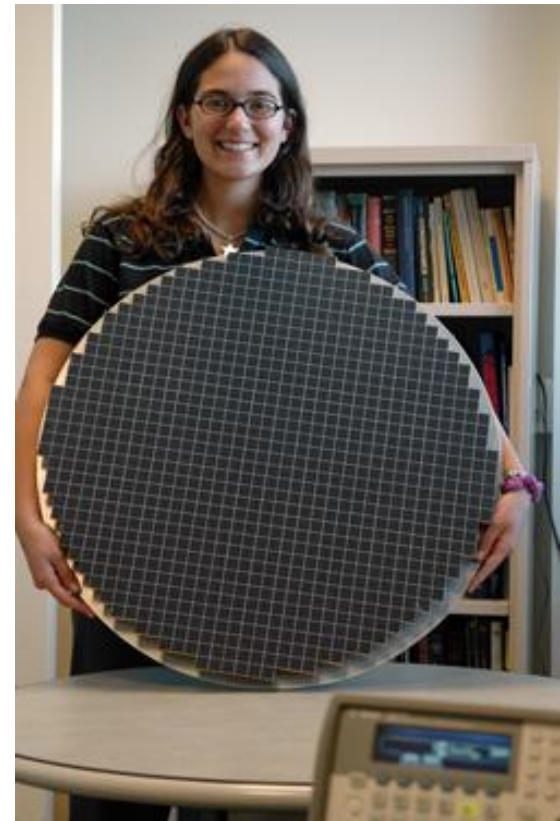

The array's diameter is 64 cm. *A representation of the CCD chips to be used in the Large Synoptic Survey Telescope project – first light 2021. Each of the 200 chips has the capacity to take a 16 mega-pixel image.* This mosaic will provide over **3.2 Gigapixels** per image.

This telescope will capture the whole southern hemisphere sky every 3 nights.

LSST: <http://www.youtube.com/watch?v=dNjXPq8clbo> , <http://www.lsst.org/lsst/>

Growth of Primary Mirror Size

Telescope Growth: Largest Telescope

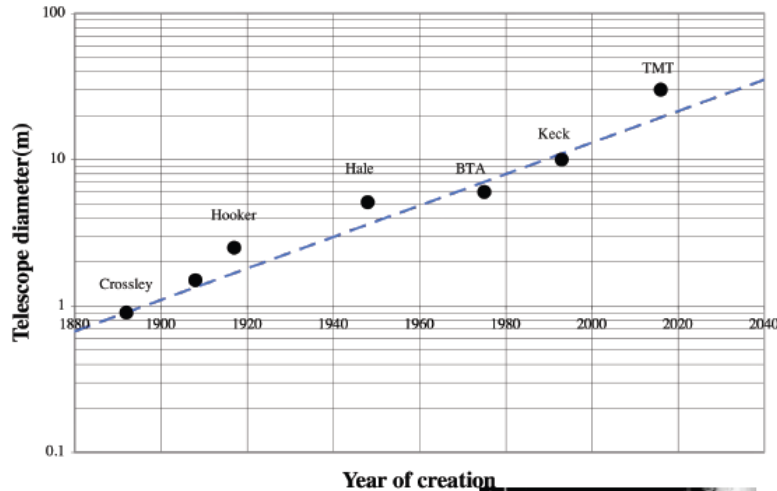

Doubling time ~ 28 yrs

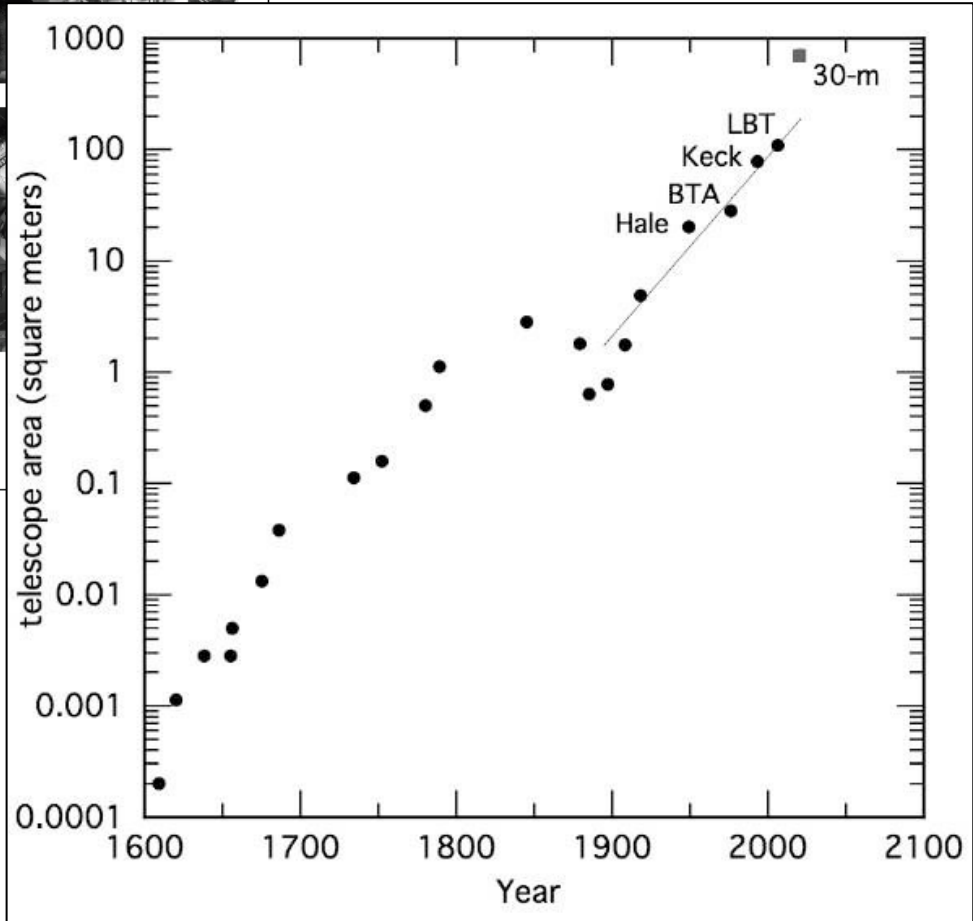
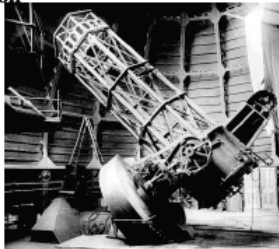

(Top) "History of the Keck Observatory: A personal recollection", Jerry Nelson, PPT presentation, 2007 December 19

(Right) "New Generation Ground-Based Optical/Infrared Telescopes", Alan T. Tokunaga and Robert Jedicke, AP2006

Newer Primary Mirror Designs



Keck Telescope, Mauna Kea, Hawaii

Right: The Large
Binocular Telescope,
Mount Graham,
Arizona

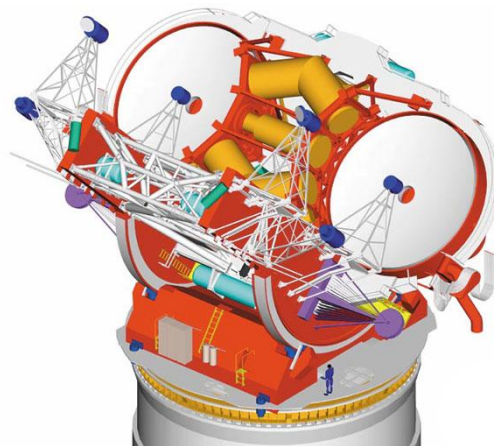

Active Optics vs. Adaptive Optics

(or De-twinkling the Stars)

- Older telescopes were made with thick heavy lenses and supporting structure that had minimal flexure, but this became impractical as lenses started to exceed 5 meters in diameter.
- **Active optics** is a technology used with reflecting telescopes developed in the 1980s, which actively shapes a telescope's mirrors to prevent deformation due to external influences such as **gravity, wind, temperature, mechanical stress**. Active optics is accomplished at the primary mirror.
- Active optics should not be confused with **adaptive optics**, which operates on a much shorter timescale to compensate for **atmospheric effects**, rather than for mirror deformation. The influences that active optics compensate are intrinsically slower (1 Hz) and have a larger amplitude in aberration. Adaptive optics on the other hand corrects for atmospheric distortions that affect the image at 100–1000 Hz. Adaptive optics is accomplished at a secondary mirror or even one further down the processing chain.

Source: http://en.wikipedia.org/wiki/Active_optics

The problem with the atmosphere

Note that a mountain-top observatory is above many types of clouds as well as most of the water vapor that blocks infrared radiation.



Tip -Tilt, Lucky Imaging and Adaptive Optics

In 1957, physicist Robert Leighton of Cal Tech partially corrected the **atmospheric blurring** at the 60-inch telescope on Mount Wilson to produce the sharpest photographs of Jupiter and Saturn up to that time. He did this by **tilting the secondary mirror several times a second** (a technique now called "tip-tilt" correction) to eliminate or reduce the rapid motion of the image.

Tip-tilt yielded an improvement of about a factor of 2 or 3 in sharpness but an improvement by another factor of 10 was needed in order to eliminate atmospheric blurring altogether. New techniques [**known as adaptive optics**] first became available in the 1970's,* largely as a result of U.S. Department of Defense research on methods of keeping a laser beam sharply focused in the atmosphere.

This work was declassified in the 90's and adopted by astronomers in the 2000's.

* In Lexington at Itek and Lincoln Labs. See:

http://www.ll.mit.edu/publications/journal/pdf/vol05_no1/5.1.1.opticsresearch.pdf

The report says: "Over the past two decades several hundred people have contributed significantly to the adaptive optics research program at Lincoln Laboratory "

Before Adaptive Optics

Lucky Imaging

- Used before Adaptive Optics, but still in use
- It was the method used to first determine that there is a black hole at the center of the Milky Way – later studied in more detail with AO
- It sort of like
 - taking a high speed video of an object
 - throwing out the extremes usually based on some criteria like the Strehl ratio (can throw out a fairly high percentage),
 - and aligning the rest (shift-and-add, a.k.a. image-stacking method)
 - free software is now available to do this with armature equipment
- Down side: only a fraction of the observation time is used
- See:
 - http://en.wikipedia.org/wiki/Lucky_imaging
 - <http://lighthouseinthesky.blogspot.com/2011/11/lucky-imaging.html> (Moon video)

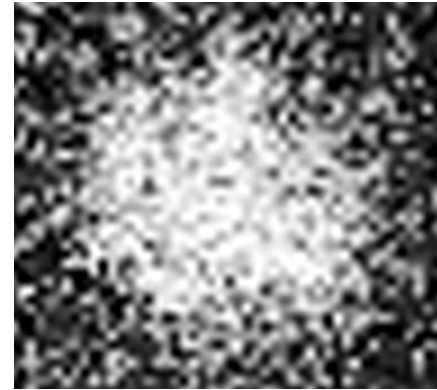

Single exposure with very low image quality, not selected for Lucky Imaging.

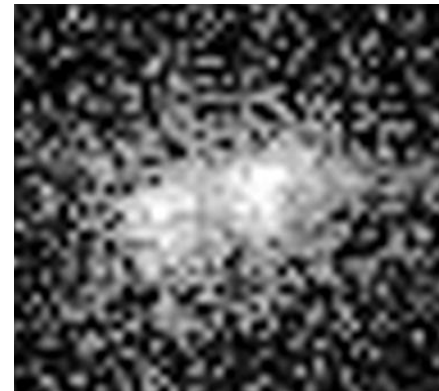

Single exposure with very high image quality, selected for Lucky Imaging.

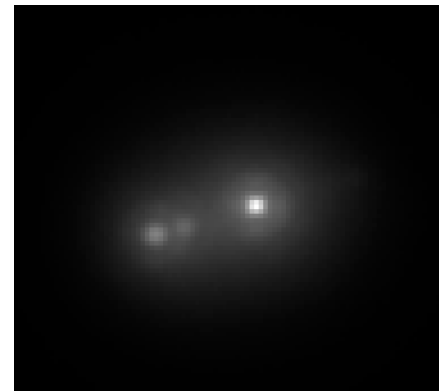

The image shows the 5,000 (10% selection) best images added together with the brightest pixel in each image moved to the same reference position.

Adaptive Mirror Concept

- First Adaptive Optics system used for astronomy purposes was developed at the Lick Observatory 1994.
- Generally the secondary mirror is flexed (or it could be the third or fourth mirror in the optical path).
- The light from a nearby guide star is kept from moving around.

For the wavefront sensor see:
http://www.vikdhillon.staff.shef.ac.uk/teaching/phy217/telescopes/phy217_tel_adaptive.html **Worth Showing**

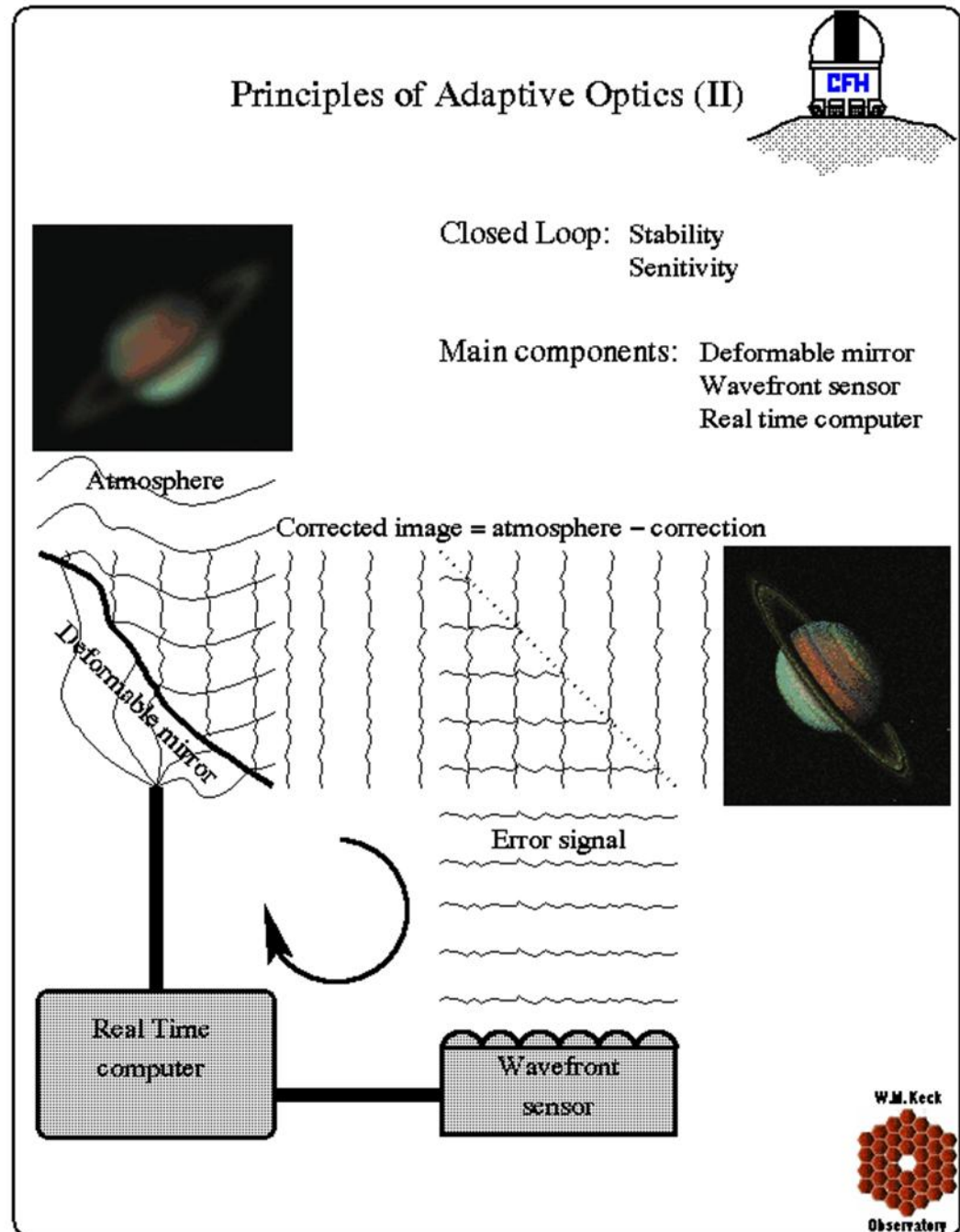

Laser guide star

- To use adaptive optics to focus on a faint object **you need a bright object (star) near by**. You use the adaptive system to focus the bright object and that in turn also focuses the faint object.
- The problem is that with a narrow field of view telescope less than 1% of the sky has a bright object close enough.
- So astronomers use an **artificial “laser guide stars”** to compensate for the turbulence.
- The laser excites a **sodium layer in the atmosphere at an altitude of ~ 90 km** with pulses of light with a wavelength tuned to make the layer fluoresce.
- A detector determines if the wavefront is flat & if not it adjusts the mirror through a feed back servo system to try to make it flat.
- **In late 2004 Keck II** was the first large telescope to have a LGS working for near IR adaptive optics – so at this point ground-based **became \approx equal to Hubble**
- You have to be careful
 - not to disturb airplanes or satellites passing overhead, and
 - on mountain top observatories with multiple telescopes each with a laser guide star you have to keep the beams separated.

Laser Guide Stars

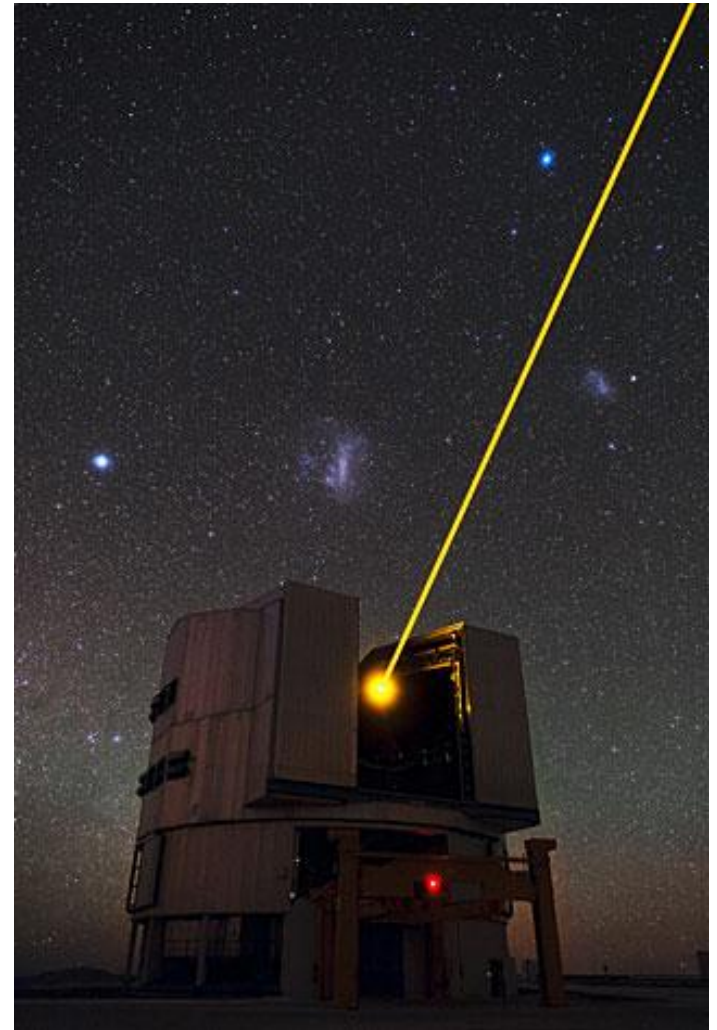

Removal of atmospheric effects with adaptive optics

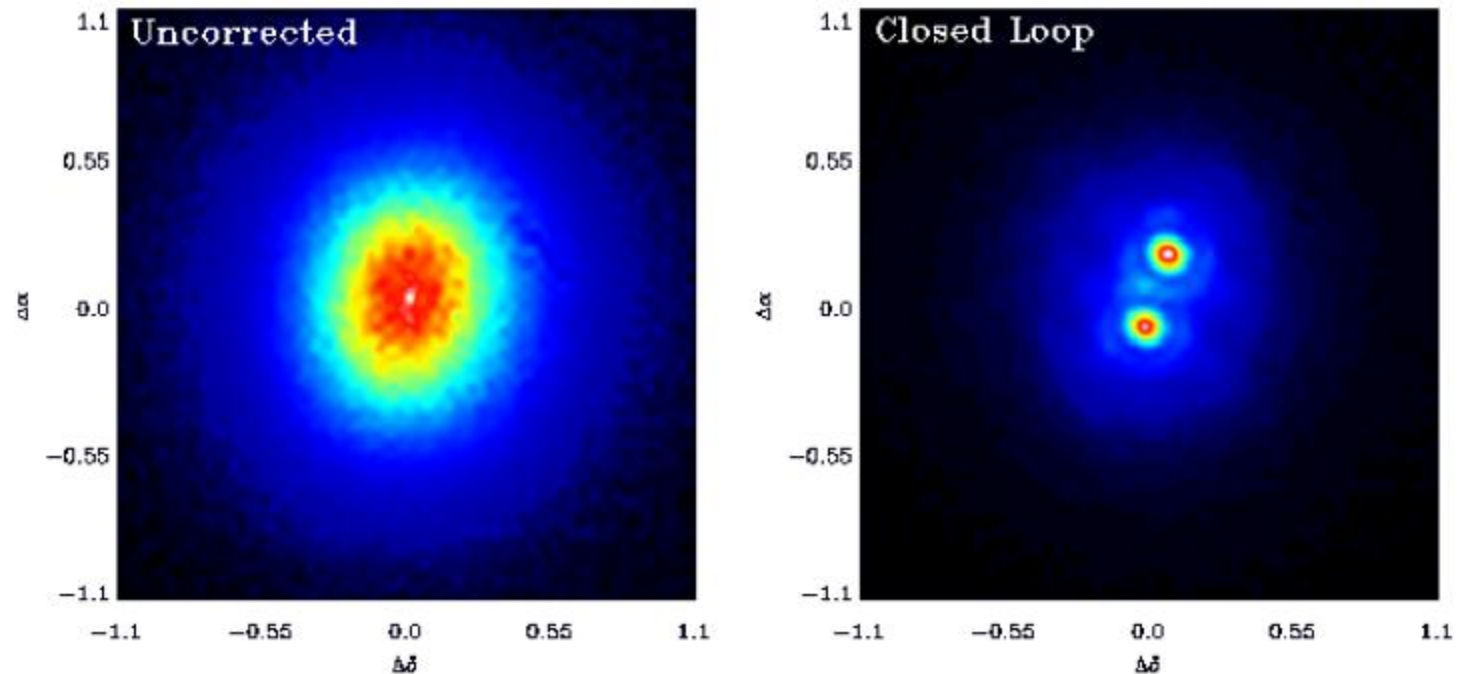

From: http://keckobservatory.org/images/files/podcast/Bolte_Hawaii09.pdf

Compare AO with seeing-limited observations and Hubble Space Telescope



Neptune at H band: $\lambda = 1.6 \mu\text{m}$

Keck Telescope
no AO

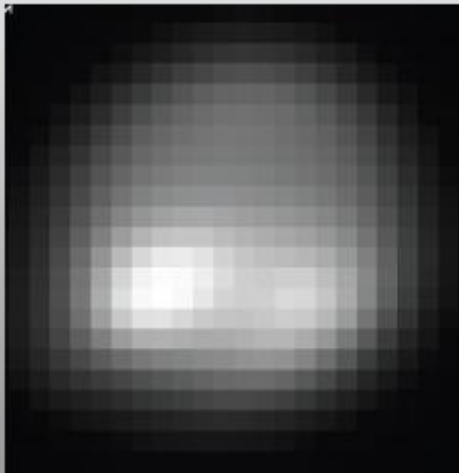

10 meter telescope

Hubble Space Telescope
NICMOS camera

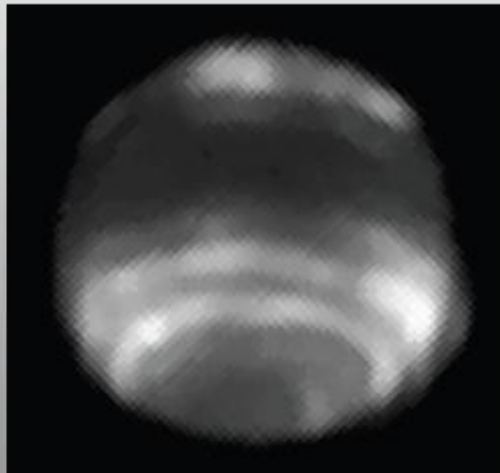

2.4 meter telescope

Keck Telescope
with AO

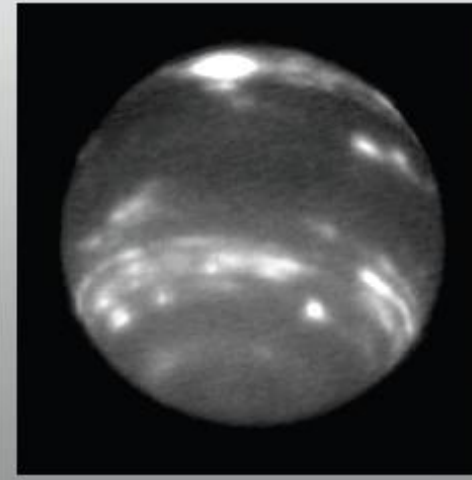

10 meter telescope

~ 2 arc sec

(Three different dates and times)

Improved resolution with adaptive optics

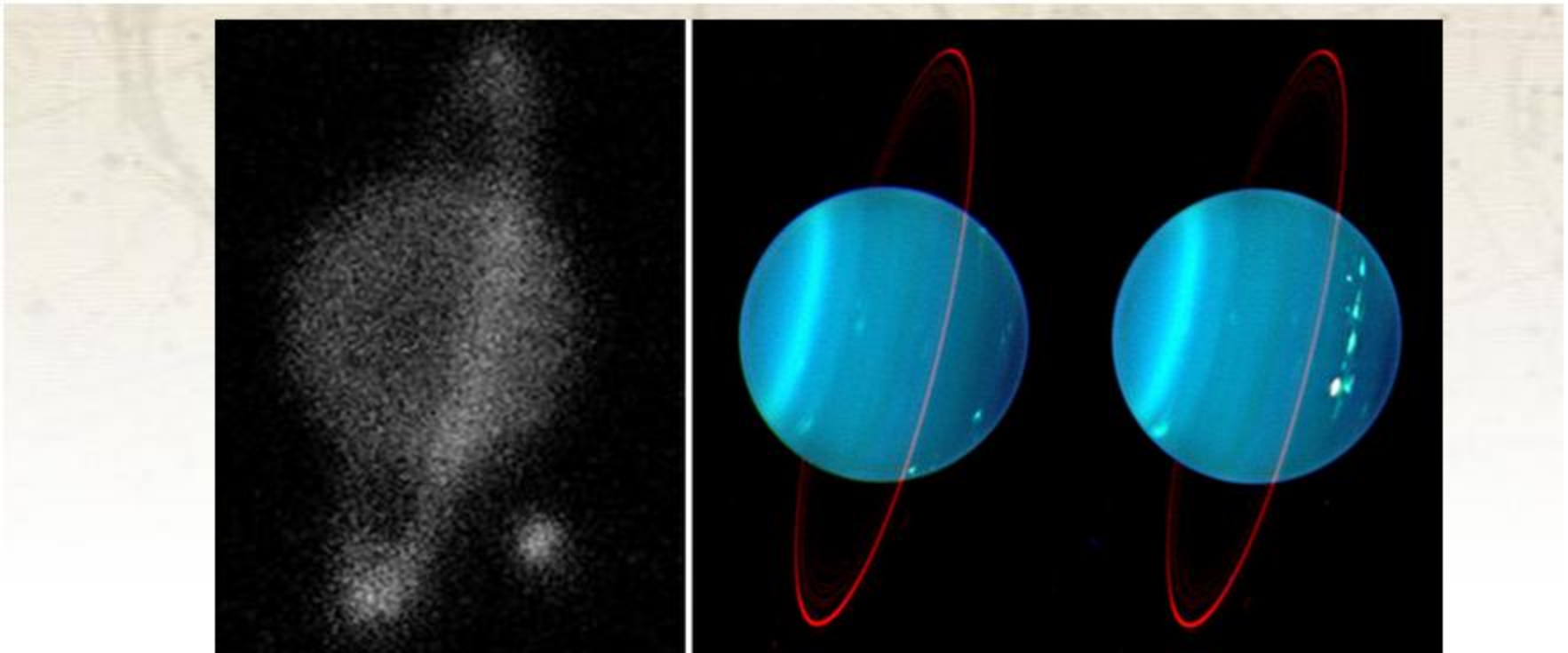

Images: (Left) The planet Uranus without adaptive optics. Image courtesy of Keck Observatory. (Right) Both hemispheres of the planet Uranus with adaptive optics. By L. Sromovski.

The evolution of adaptive optics (AO) technology spans the past several decades. AO was first proposed by astronomer Horace Babcock in 1953, in a paper titled "The Possibility of Compensating Astronomical Seeing." It took a few decades longer to develop the technological precision necessary to manufacture a successful AO system.

Other recent large telescope design changes

- **MOUNTS:** Altitude-azimuth (alt-az) mounts (as opposed to equatorial mounts) reduce the size of the required telescope dome enclosure. The enclosure for the 10m Keck telescopes is about the same size as the enclosure for the 5m Hale telescope at Mt. Palomar.
- **POLISHING:** Advances in mirror casting and computer controlled mirror polishing allow the production of larger primary mirrors with shorter focal lengths. A shorter focal length allows the telescope structure to be smaller, thus lowering the weight and cost of the telescope. Keck also developed a method to greatly simplifying polishing and re-polishing its mirrors.
- **DOMES AIRFLOW CONTROL:** Advances in reducing dome “seeing” have led to significant improvement in image quality. Dome seeing is caused by air currents and temperature differences near and within the dome, especially differences between the mirror and the surrounding air. To reduce dome seeing, it is necessary to flush the dome with outside air at night, refrigerate it during the daytime, and cool the primary mirror to about 0.5 °C below the ambient air temperature. Newer telescope designs include air flow analysis using computational fluid dynamic (CFD) software.

Other recent large “telescope” design changes

- **POST PROCESSING:**

- Image stitching, the process of combining multiple images into one
- Compensate for differences in pixel sensitivity, noise or dead pixels
- Remove anomalies (passing meteors, satellites)
- Removing lines from CCD mosaics →
- Color enhancement or false colors for non-visible wavelengths
- Improve brightness, sharpness, contrast
- Maybe rotate the image

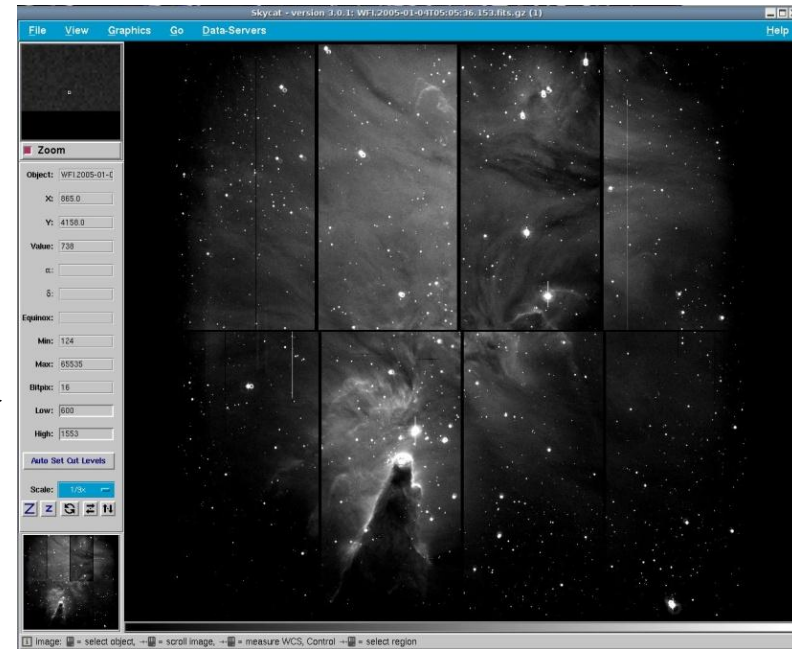

See: <http://www.youtube.com/watch?v=A4W7dvoWBGU>
<http://www.pbs.org/wgbh/nova/space/hubble-telescope.html>

- **DATA MANAGEMENT:** The **LSST** (Large Synoptic Survey Telescope) camera is expected to take up to 30 Terabytes of data per night. Managing and effectively data mining the enormous output of the telescope is expected to be the most technically difficult part of the project. Initial computer requirements are estimated at 100 teraflops of computing power and 15 petabytes of storage, and rising as the project collects additional data.

Post Processing Examples

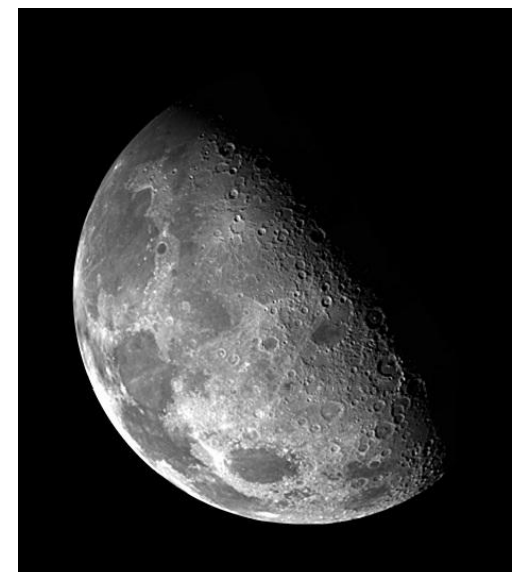
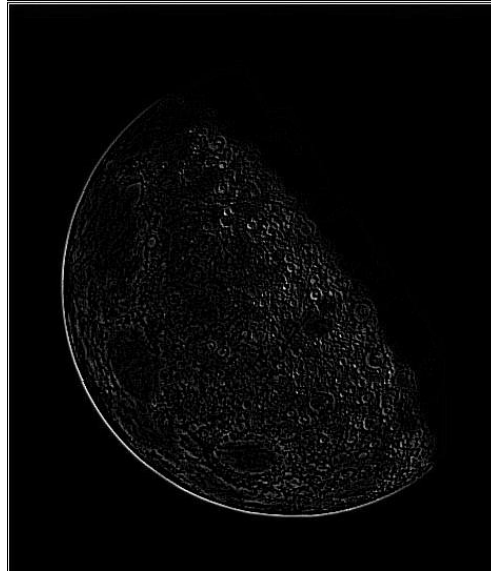

<http://stackoverflow.com/questions/11878281/image-sharpening-using-laplacian-filter>
<http://www.pixastic.com/lib/docs/actions/laplace/>



<http://www.astrocruise.com/articles/decon/decon.htm>

What's Next?

Extremely Large Telescopes

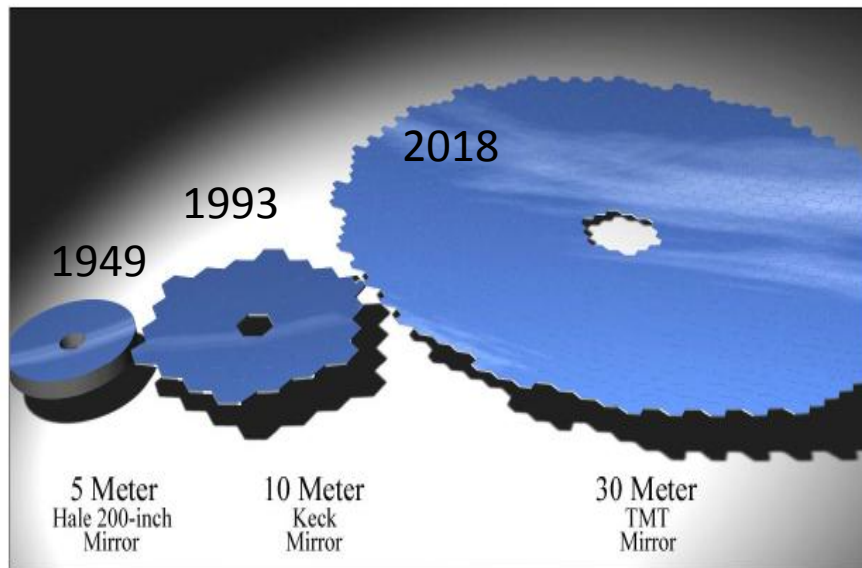

The Thirty Meter Telescope (TMT)

planned for Mauna Kea ~2018 designed for observations from the near-ultraviolet to the mid-infrared (0.31 to 28 μm wavelengths). The centerpiece of the TMT Observatory will be a Ritchey-Chrétien telescope with a 30 meter diameter primary mirror. This mirror will be segmented and consist of 492 smaller (1.4 m), individual hexagonal mirrors.

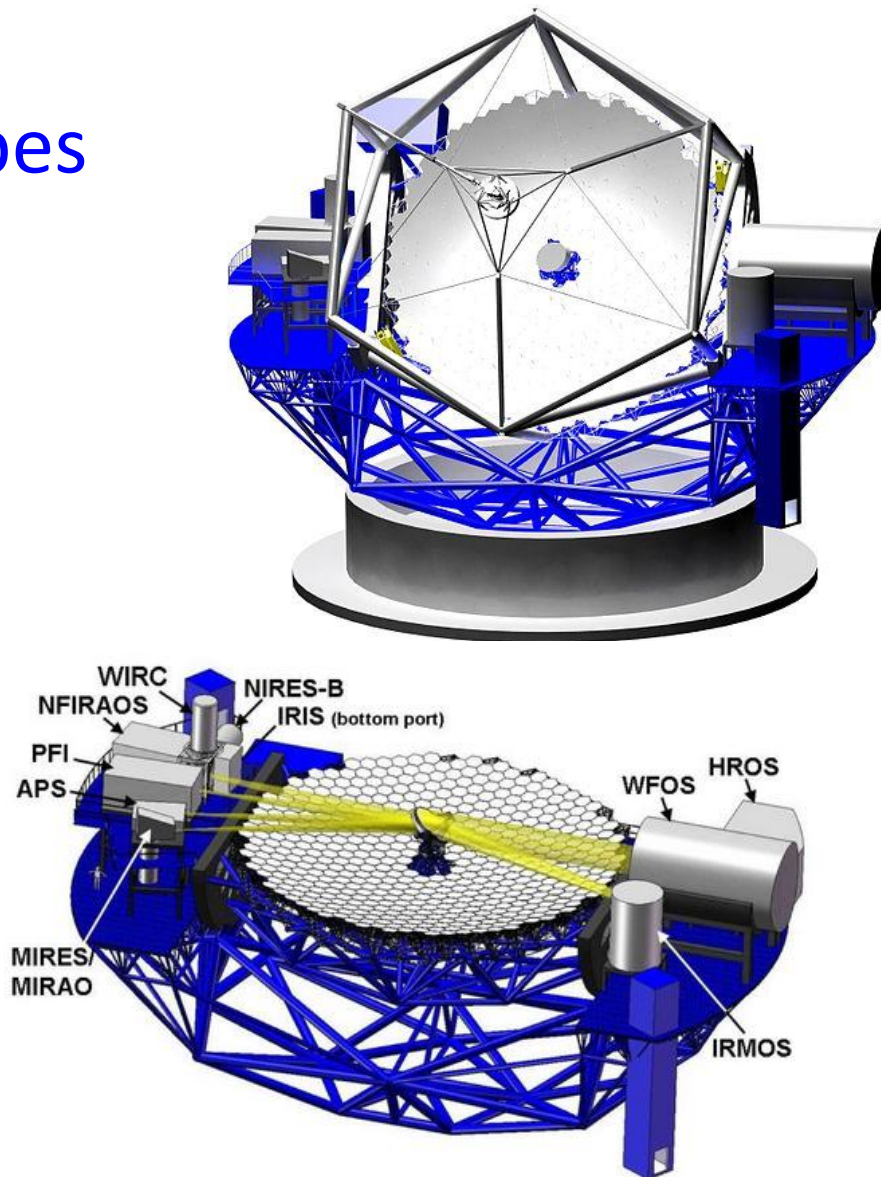

What's Next? Extremely Large Telescopes

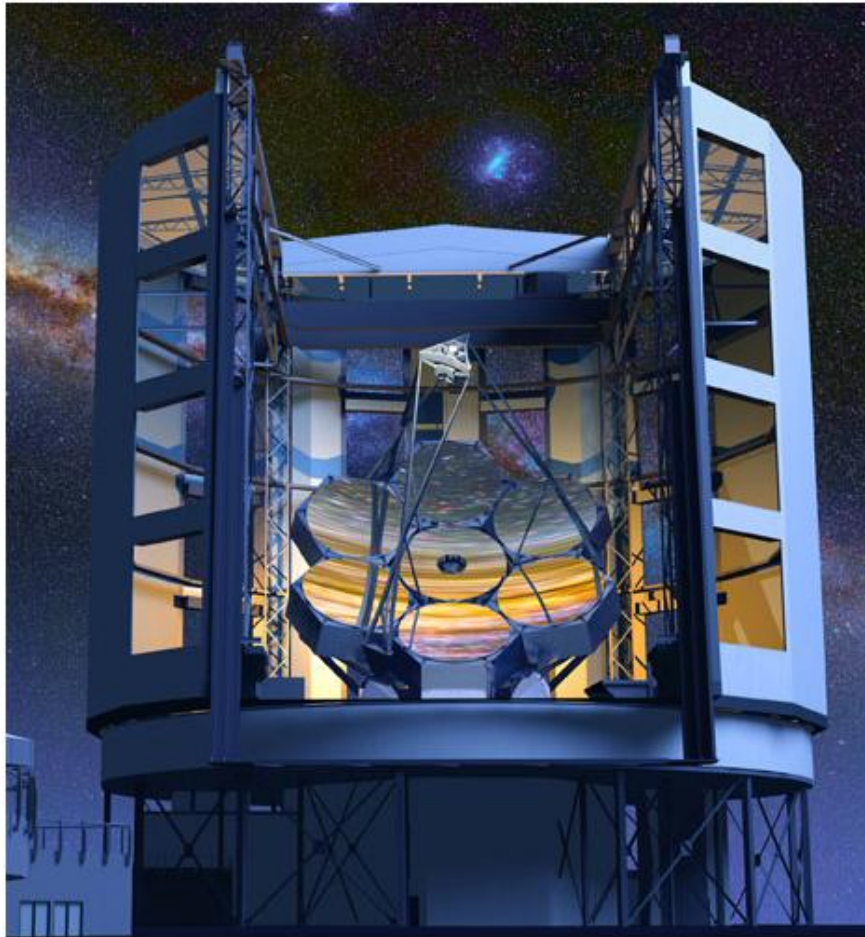

The **Giant Magellan Telescope** will use seven 8.4m mirrors. It's scheduled for first light in Chile in 2020.

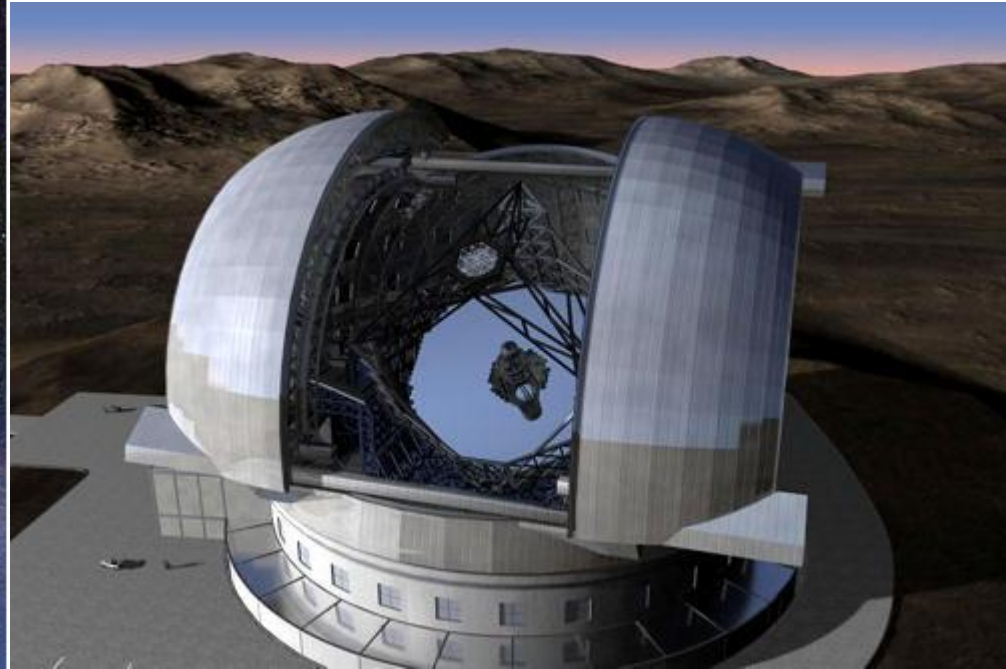

The **European Extremely Large Telescope** will also be located in Chile with first light in 2022. The primary mirror for the 39.3m design will be composed of 798 hexagonal segments, 1.45 meters across and only 50 mm thick.

See: http://en.wikipedia.org/wiki/Extremely_large_telescope

Interesting Presentations and Reports

- Lucky imaging and Adaptive optics
 - <http://www.youtube.com/watch?v=gMDCZHNvY7A> (33 min. video)
 - http://www.vikdhillon.staff.shef.ac.uk/teaching/phy217/telescopes/phy217_tel_adaptive.html (WEB site with GOOD animations)
- Keck
 - Keck facts (incl. some good illustrations): <http://spacecraftkits.com/KFacts.html>
 - 400 years of Discovery (good adaptive optics summary, PDF slides with audio): <http://keckobservatory.org/education/podcast/2009/>
- TMT (Thirty Meter Telescope)
 - <http://www.tmt.org/gallery/video/tmt-overview> (5 min. video, about science capability)
 - <http://www.youtube.com/watch?v=zXIsJmCYdyo> (6 min. video, mostly about mirrors))
- European Southern Observatory – Adaptive Optics, Black Hole in Milky Way and Interferometry
 - http://www.youtube.com/watch?v=Muk4F_LvbYs (6 min. video)
- Large Binocular Telescope secondary mirror adaptive optics system
 - http://www.liveleak.com/view?i=49b_1358048879 (3 min. video)
- Keeping track of everything in orbit and daylight viewing
 - <http://www.youtube.com/watch?v=dtmKBEG4cEA> (12 min. video)
- Center for Adaptive Optics - University of California Science and Technology Center
 - <http://cfao.ucolick.org/links.php> (A large number of AO links)

The following slides are variations of earlier slides or back-ups to help explain things.

Black hole at center of Milky Way

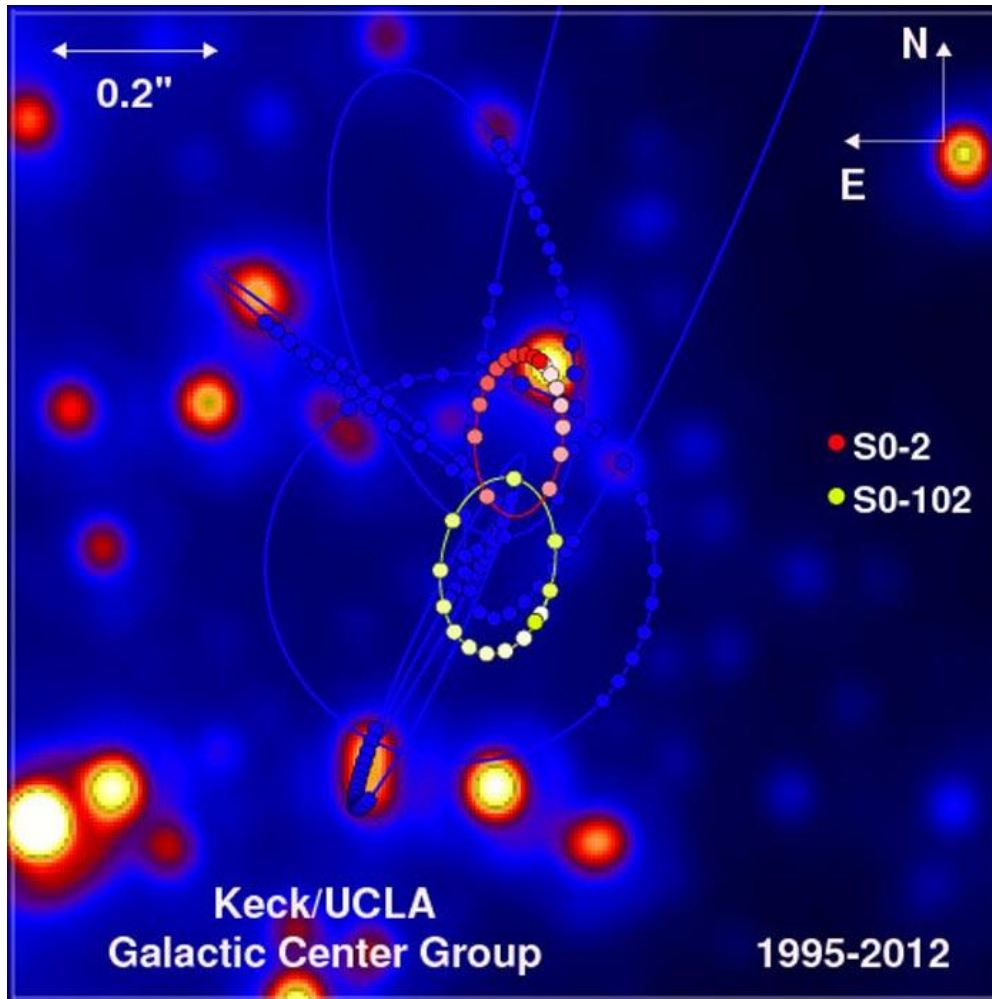

This work was conducted at infrared wavelengths using the [Keck](#) telescope in Hawaii and the [VLT](#) in Chile; initially using [Lucky Imaging](#) and subsequently with [Adaptive Optics](#).

It is now believed that most, if not all, large galaxies have black holes at their centers.

Note that the period of observation has been long enough to see some complete orbits.

See <http://www.youtube.com/watch?v=KCADH3x56eE> (20 min. video)
and <http://blackholes.stardate.org/research/milky-way-dark-heart.php>
and <http://video.pbs.org/video/980039078/#> (52 min. NOVA show)

Major Types of Telescopes (p. 4b of 5)

News Flash (21 March 2013): The European **Planck Observatory**, which is the latest μ wave probe launched in 2009, has released data that indicates the universe is 13.81 ± 0.05 billion years old, up from a value of 13.77 ± 0.06 from **WMAP** and other estimates.

http://www.esa.int/Our_Activities/Space_Science/Planck/Planck_reveals_an_almost_perfect_Universe

Per Wikipedia: The age of the universe is defined in physical cosmology as the time elapsed since the Big Bang. The best estimate of the age of the universe, as of 22 March 2013, is 13.798 ± 0.037 billion years within the Lambda-CDM concordance model. http://en.wikipedia.org/wiki/Age_of_the_universe

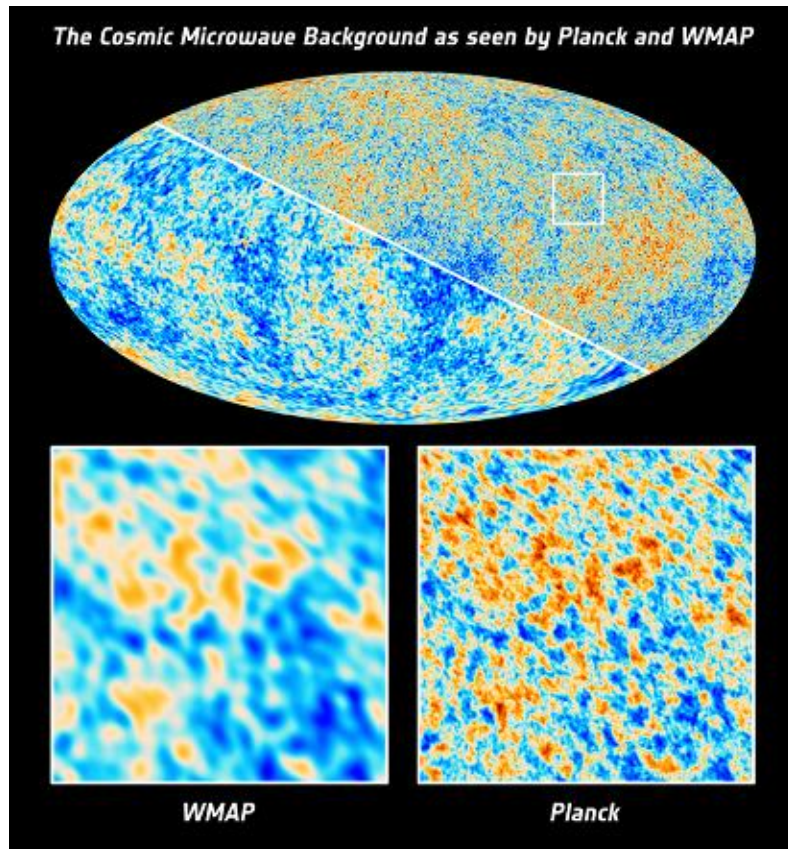

Lagrange points

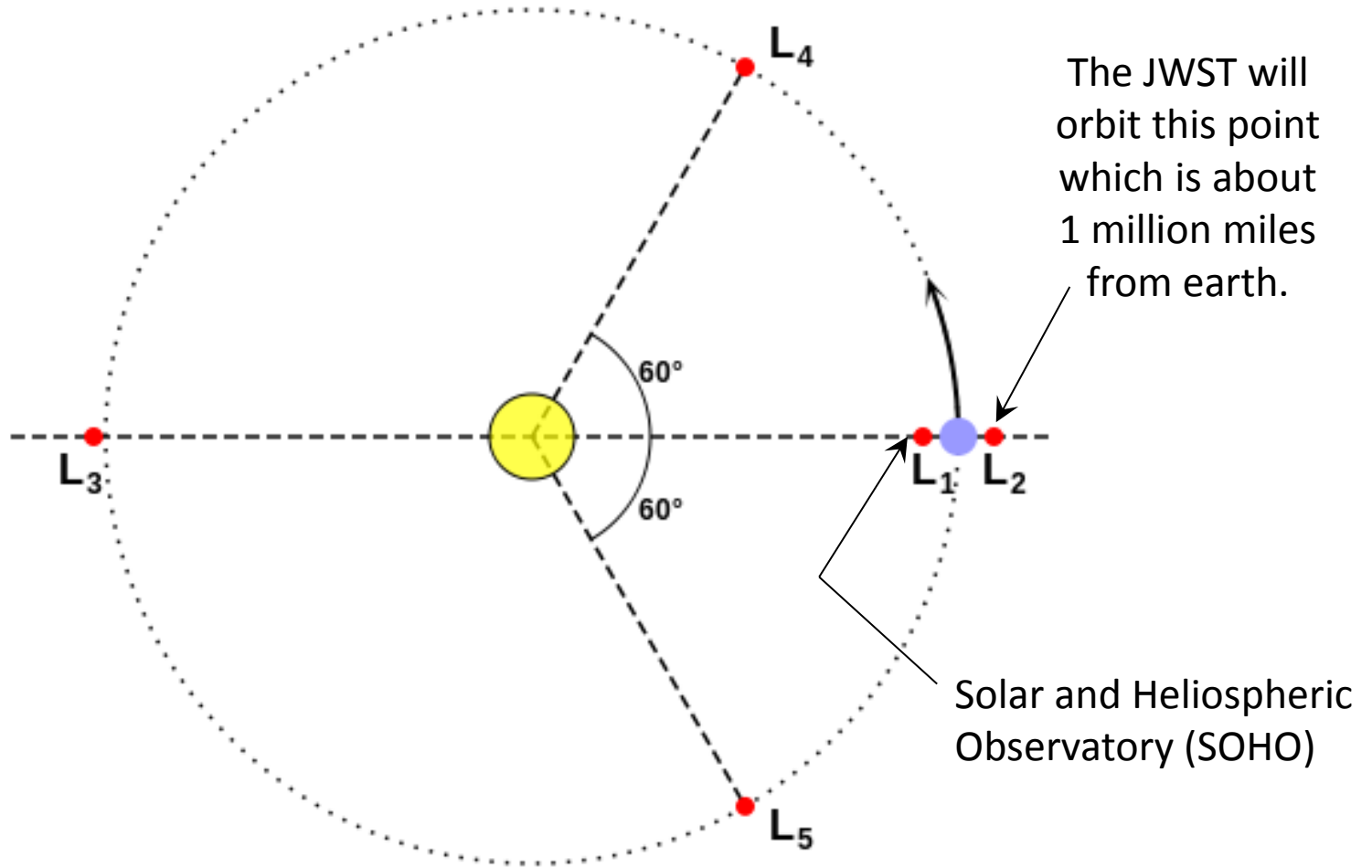

Hubble telescope (launched in 1990)
before and after the initial upgrade (1993)



Stephan's Quintet before and after second upgrade (2009)



The military has offered NASA two free Hubbles for the asking:

- <http://blogs.nature.com/news/2012/06/free-spy-telescopes-come-to-nasa-with-a-cost.html>
- <http://www.nature.com/news/the-telescopes-that-came-in-from-the-cold-1.11511>
- <http://www.astronomynow.com/news/n1211/30nrotelescopes/#.URE6vx08CS0>

Adaptive Secondary Mirror for the E-ELT

From: DEFORMABLE MIRROR SOLUTIONS FOR ELTs AND
LARGE SIZE OPTICAL COATING CAPABILITIES AT CILAS

 **M4AU for E-ELT – Preliminary Design**

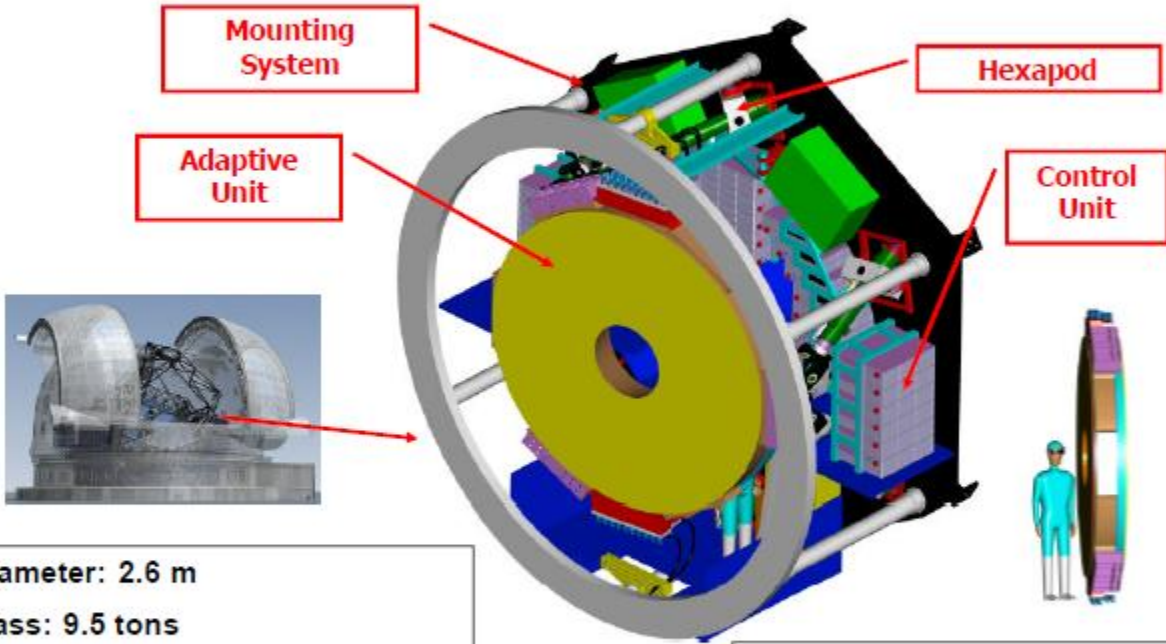

Mounting System

Hexapod

Adaptive Unit

Control Unit

- Diameter: 2.6 m
- Mass: 9.5 tons
- Optical plate rigidly mounted (not a thin shell)

- 7217 actuators
- Full stroke: 90 μm
- Electrical consumption: 4.2 kW

 This document is the property of CILAS and may not be reproduced without authorization

CILAS - 8, Avenue Buffon - Z.I. La Source - 45063 ORLEANS cedex France
Tel : +33 3 28 64 47 55 - Fax : +33 3 28 36 01 49

DPOA 10-032 – EUSPEN MEETING 13
26/11/2010

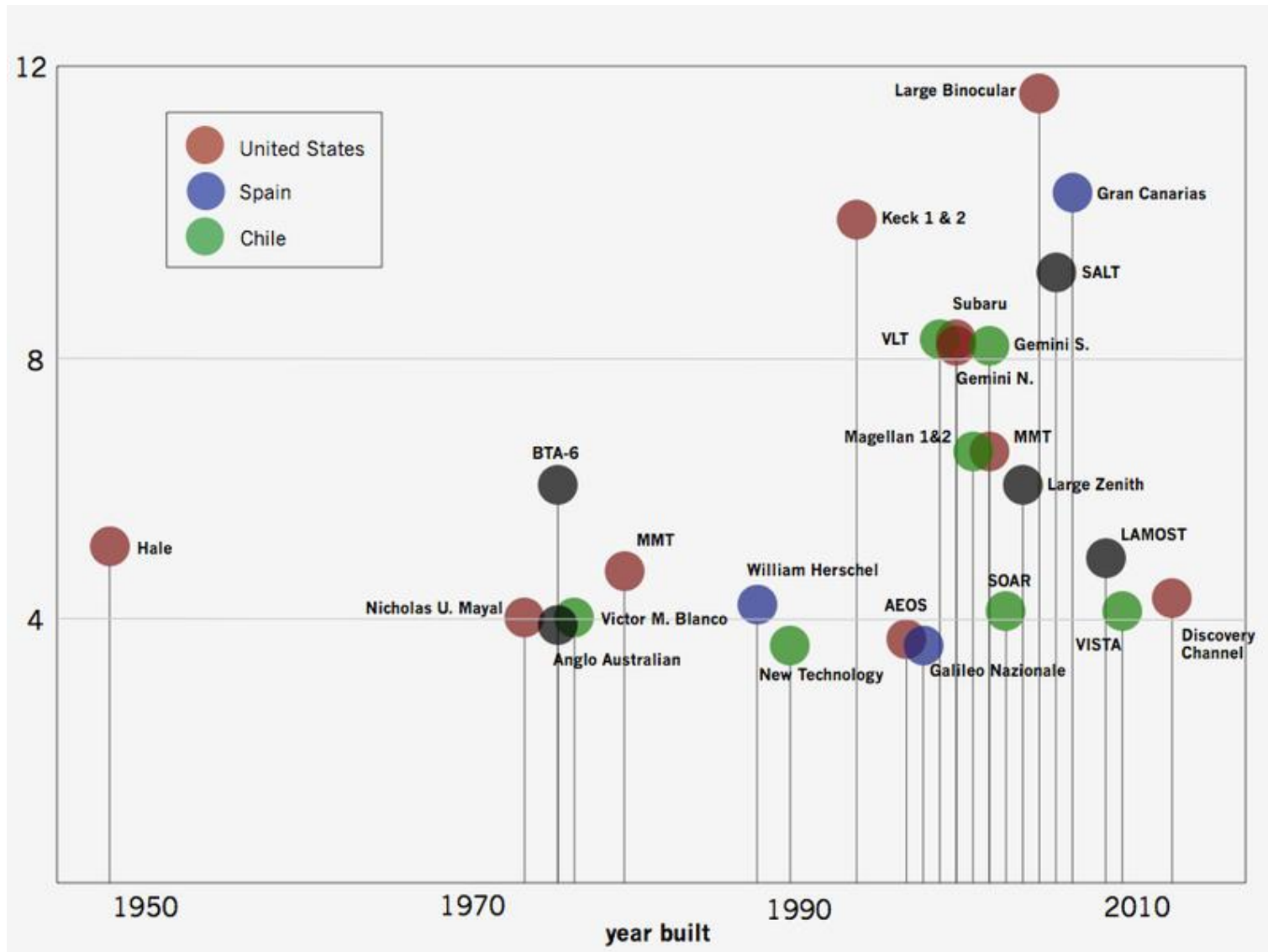

From: http://en.wikipedia.org/wiki/List_of_largest_optical_reflecting_telescopes



Il cannocchiale di Galileo

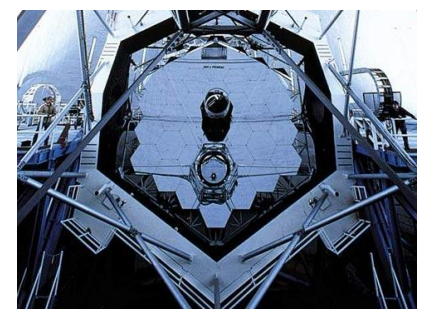
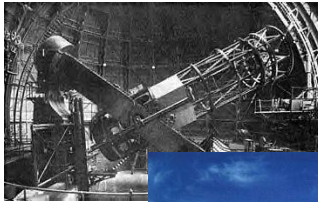
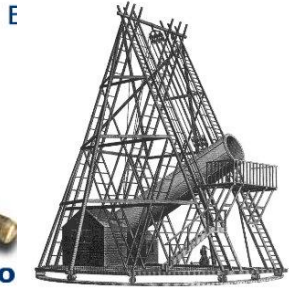

The Legacy of Large Astronomical Telescopes

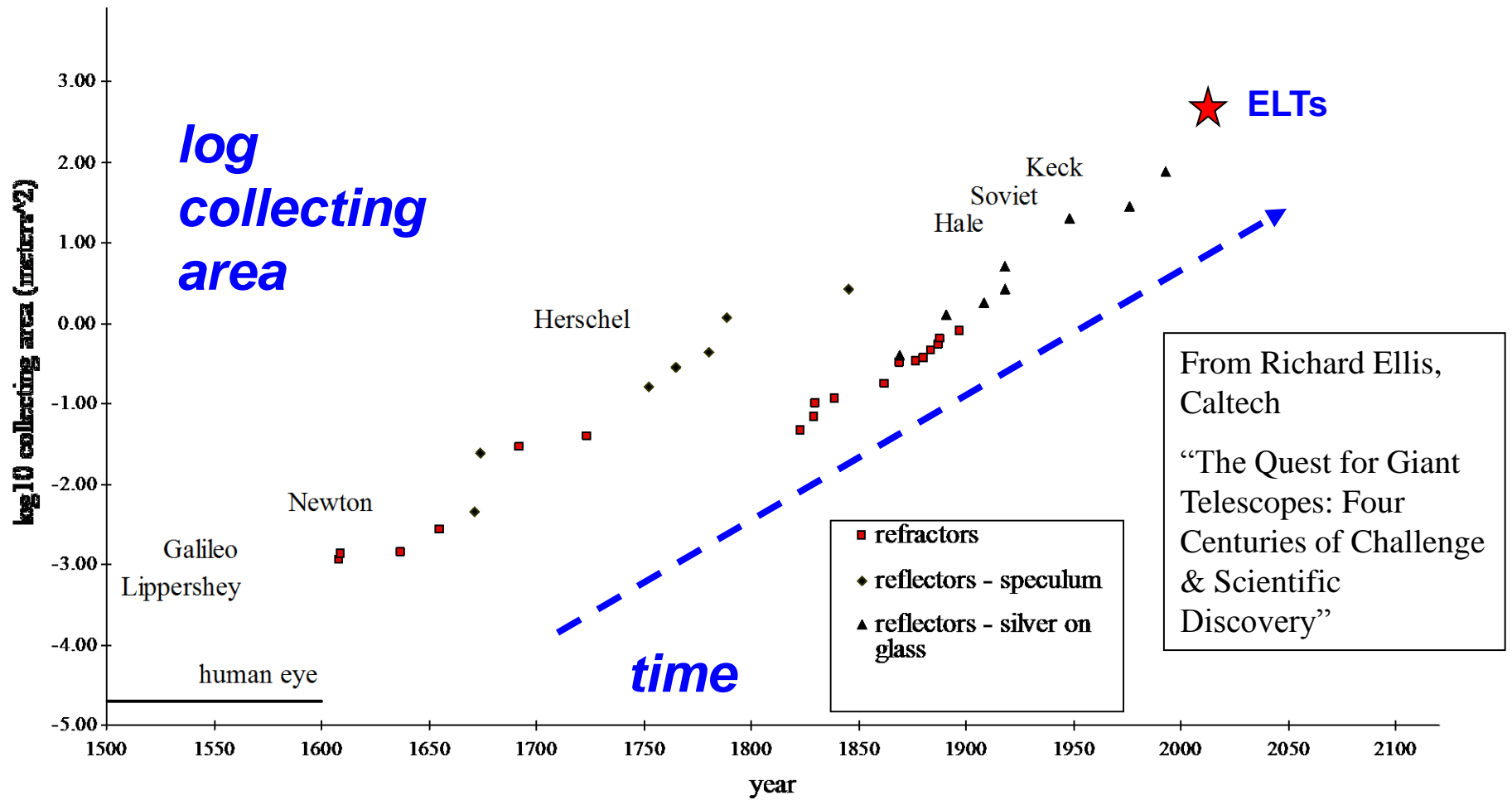

Definitions from Wikipedia

- **Astronomy** is a science involving the observation and explanation of events occurring outside Earth and its atmosphere. It includes the study of the origin, evolution, and physical and chemical properties of objects that can be observed in the sky, space, and in the whole universe.
- **Astrophysics** is the study of how stars and planets work, and how we can learn about them. Astrophysicists use physics to explain what astronomers find and see. Astrophysics is also the study of how the Universe started and how it is changing with time. This part of astrophysics is called cosmology.
- **(Physical) Cosmology** is the scholarly and academic study of questions about the ultimate fate of the universe. The subject matter of this field is studied using scholarly methodology, including the scientific method and reason. It is studied by scientists, such as astronomers and theoretical physicists; and academic philosophers, such as metaphysicians, philosophers of physics, and philosophers of space and time.

It's getting crowded on Mauna Kea

(Mauna Loa in distance)



The next eruption of Mauna Kea

Mauna Kea's peaceful appearance is misleading. The volcano is not dead. It erupted many times between 60,000 and 4,000 years ago, and some periods of quiet during that time apparently lasted longer than 4,000 years. Given that record, future eruptions seem almost certain.

From the USGS http://hvo.wr.usgs.gov/volcanowatch/archive/2000/00_06_01.html

Large Synoptic Survey Telescope (LSST)

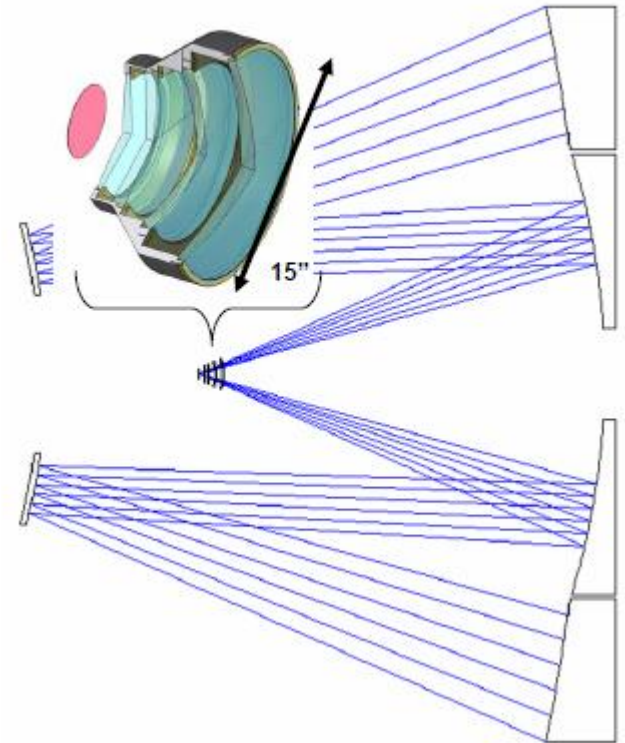
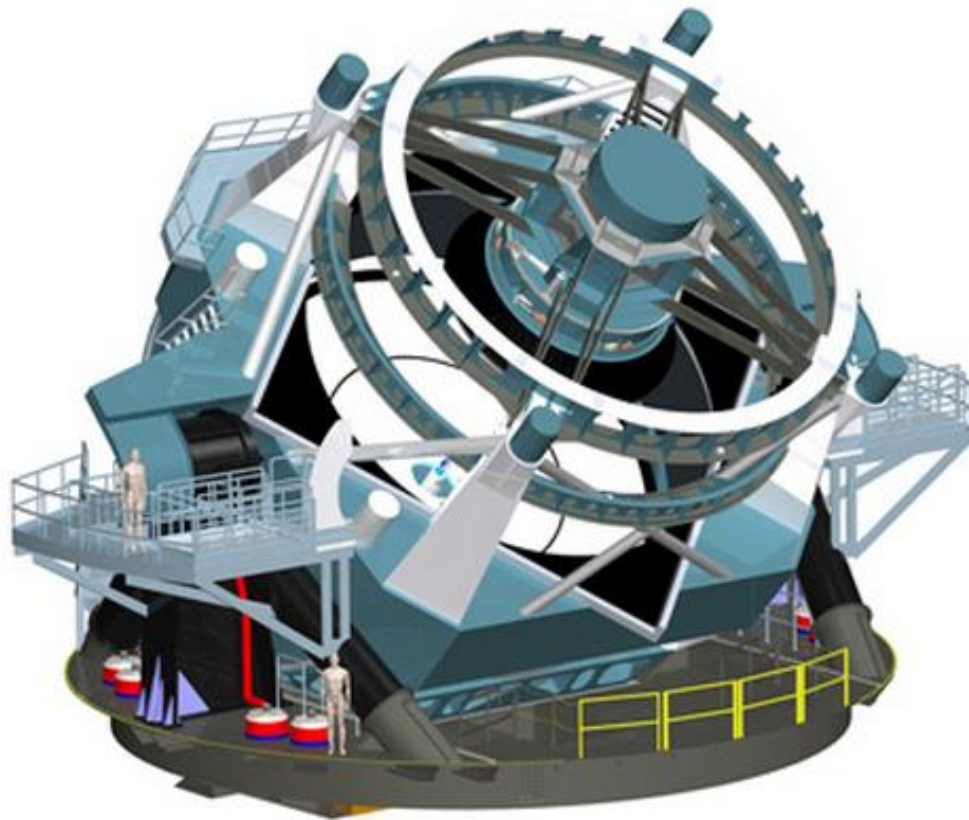

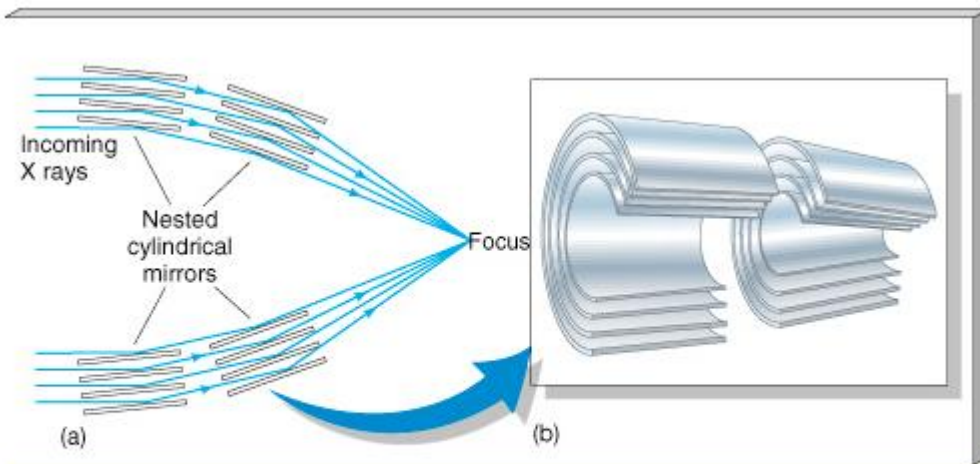

Figure 5.32 X-Ray Telescope The arrangement of mirrors in an X-ray telescope allows X-rays to be reflected at grazing angles and focused to form an image.

Penzias and Wilson stand at the 15 meter Holmdel Horn Antenna that brought their most notable discovery.

